

JVC



ENGLISH

DEUTSCH

FRANÇAIS

NEDERLANDS

CD RECEIVER
CD-RECEIVER
RECEPTEUR CD
CD-RECEIVER

KD-SH99R

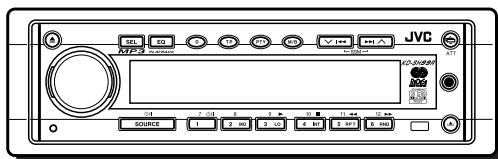
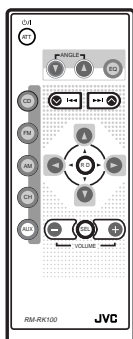
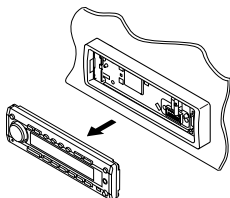

MP3 *PLAYBACK*



For installation and connections, refer to the separate manual.
Angaben zu Einbau und Verkabelung entnehmen Sie bitte der gesonderten Anleitung.
Pour l'installation et les raccordements, se référer au manuel séparé.
Zie de afzonderlijke handleiding voor details aangaande het installeren en verbinden van het toestel.

INSTRUCTIONS

BEDIENUNGSANLEITUNG
MANUEL D'INSTRUCTIONS
GEBRUIKSAANWIJZING

LVT0655-001A
[E/EX]

Position And Reproduction Of Labels

Bottom Panel of the main unit

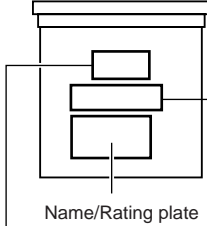

Caution:
This product contains a laser component of higher laser class than Class 1.

CAUTION: Invisible laser radiation when open and interlock failed or defeated. AVOID DIRECT EXPOSURE TO BEAM.	ADVARSEL: Usynlig laserstråling ved åbning, når sikkerhedsafbrydere er ude af funktion. Undgåudsætelse for stråling.	WARNING: Osynlig laserstråling når denna del är öppnad och spärren är urkopplad. Betrakta ej strålen.	VARO: Avattaessa ja suojalukitus ohitettaessa olet alltiina näkymättömälle lasersäteilylle. Älä katso säteeseen.
(e)	(e)	(d)	(s)

IMPORTANT FOR LASER PRODUCTS

Precautions:

1. CLASS 1 LASER PRODUCT
2. **CAUTION:** Invisible laser radiation when open and interlock failed or defeated. Avoid direct exposure to beam.
3. **CAUTION:** Do not open the top cover. There are no user-serviceable parts inside. Leave all servicing to qualified service personnel.
4. **CAUTION:** This CD player uses invisible laser radiation and is equipped with safety switches to prevent radiation emission when unloading CDs. It is dangerous to defeat the safety switches.
5. **CAUTION:** Use of controls, adjustments or performance of procedures other than those specified herein may result in hazardous radiation exposure.

How to reset your unit

Press the reset button on the front panel using a ball-point pen or similar tool.

Note:

Your preset adjustments – such as preset channels or sound adjustments – will be erased.

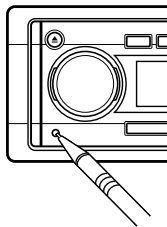

CAUTION:

NEVER insert your finger in between the control panel and the unit, as it may get caught or hurt. (See page 35.)

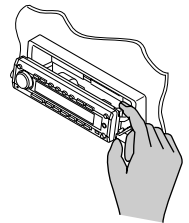

Note:

For security reasons, a numbered ID card is provided with this unit, and the same ID number is imprinted on the unit's chassis. Keep the card in a safe place, as it will help the authorities to identify your unit if stolen.

BEFORE USE

***For safety....**

- Do not raise the volume level too much, as this will block outside sounds, making driving dangerous.
- Stop the car before performing any complicated operations.

***Temperature inside the car....**

If you have parked the car for a long time in hot or cold weather, wait until the temperature in the car becomes normal before operating the unit.

Thank you for purchasing a JVC product. Please read all instructions carefully before operation, to ensure your complete understanding and to obtain the best possible performance from the unit.

CONTENTS

How to reset your unit	2	SOUND ADJUSTMENTS	27
LOCATION OF THE BUTTONS	4	Adjusting the sound	27
Control panel	4	Selecting preset sound modes	28
Remote controller	5	Storing your own sound adjustments	29
Preparing the remote controller	6	OTHER MAIN FUNCTIONS	30
BASIC OPERATIONS	7	Setting the clock	30
RADIO BASIC OPERATIONS	8	Changing the general settings (PSM)	30
Listening to the radio	8	Assigning names to the sources	34
Storing stations in memory	9	Changing the control panel angle	35
Tuning into a preset station	10	Detaching the control panel	36
RDS OPERATIONS	11	EXTERNAL COMPONENT OPERATIONS ..	37
What you can do with RDS EON	11	Playing external components	37
Other convenient RDS functions and adjustments	14	CD CHANGER OPERATIONS	39
CD OPERATIONS	17	Playing CDs	39
Playing a CD	17	Selecting CD playback modes	40
Locating a track or particular portion on a CD	18	DAB TUNER OPERATIONS	41
Selecting CD playback modes	18	Tuning into an ensemble and one of the services	41
Playing a CD Text	19	Storing DAB services in memory	43
Prohibiting disc ejection	19	Tuning into a preset DAB service	44
MP3 INTRODUCTION	20	What you can do more with DAB	44
What is MP3?	20	ADDITIONAL INFORMATION	45
How are MP3 files recorded and played back?	20	TROUBLESHOOTING	46
MP3 OPERATIONS	22	MAINTENANCE	48
Playing an MP3 disc	22	Handling discs	48
Locating a file or particular portion on an MP3 disc	23	SPECIFICATIONS	49
Selecting MP3 playback modes	26		

About the demonstration mode (DEMO MODE)...

When shipped from the factory, "DEMO MODE" is set to "DEMO ON" in this unit. The following demonstration, introducing the main features equipped with this unit, will appear on the display automatically if no sound comes in for 3 minutes. (See page 33.)

- **MP3** : (Enables you to play MP3 discs.)
- **24bit DAC** : (24 bit digital-analog converter: Gives you a high quality sound after D/A conversion.)
- **HS TUNER** : (High-sensitivity Tuner: Enables a fine reception of stations.)
- **EQUALIZER** : (Enables you to fine-adjust the sound to match your preference.)
- **SUB WOOFER** : (Enables you to connect a subwoofer and to adjust its output level.)

CAUTION on Volume Setting

CDs produce very little noise compared with other sources. If the volume level is adjusted for the tuner, for example, the speakers may be damaged by the sudden increase in the output level. Therefore, lower the volume before playing a disc and adjust it as required during playback.



LOCATION OF THE BUTTONS

ENGLISH

Control panel

16 numbered callouts on the control panel diagram:

- 1: Eject button
- 2: Control dial
- 3: SEL (select) button
- 4: EQ (equalization) button
- 5: D (display) button
- 6: TP (traffic programme) button
- 7: PTY (programme type) button
- 8: M/B (mode/band) button
- 9: Playback control buttons (stop, play/pause, fast forward, fast reverse)
- 10: ATT (angle/attenuator) button
- 11: Auxiliary input jack
- 12: Control panel release button
- 13: Remote sensor
- 14: Number buttons (1-6)
- 15: SOURCE button
- 16: Reset button

- 1 ▲ (eject) button
- 2 Control dial
- 3 SEL (select) button
- 4 EQ (equalization) button
- 5 D (display) button
- 6 TP (traffic programme) button
- 7 PTY (programme type) button
- 8 M/B (mode/band) button
- 9 ▼ ◀▶▶▶ ▲ buttons
 - Also function as SSM buttons when pressed together.
- 10 ⏻ ATT (angle/attenuator) button
- 11 Auxiliary input jack
- 12 ⏻ (control panel release) button
- 13 Remote sensor
- 14 Number buttons
 - MO (monaural) button
 - LO (local) button
 - INT (intro scan) button
 - RPT (repeat) button
 - RND (random) button
 - DVD/Video component operation buttons
- 15 SOURCE ⏻/I (standby/on) button
- 16 Reset button

How to use M/B (mode/band):

If you press M/B (mode/band), this button functions as the Mode button and the unit goes into functions mode whereby the number buttons and the ◀▶▶▶ buttons work as different function buttons.

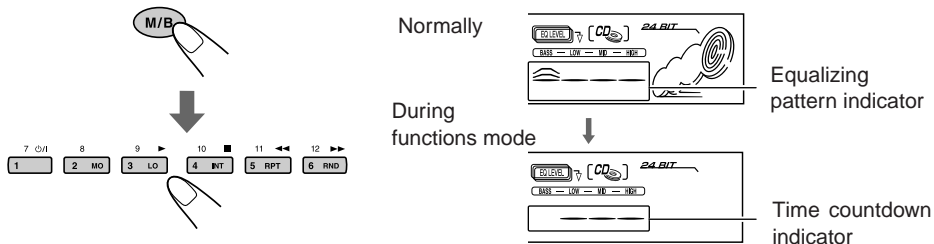

To use these buttons as number buttons and ◀▶▶▶ buttons again after pressing M/B (mode/band), wait for 5 seconds without pressing any number button until the functions mode is cleared.

- Pressing M/B (mode/band) again also clears the functions mode.



Remote controller

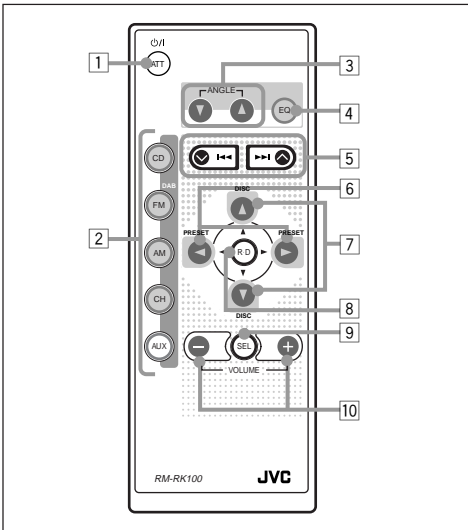

- 1 • Turns on the unit if pressed when the unit is turned off.
- Turns off the unit if pressed and held until “SEE YOU” appears on the display.
- Drops the volume level if pressed briefly, and “ATT” flashes on the display. Press again to resume the volume.
- 2 • CD : Selects CD player.
- FM :
 - Selects FM tuner.
 - Each time you press the button, FM band (FM1, FM2 and FM3) changes.
 - Selects DAB tuner if pressed and held.*
 - Each time you press and hold the button, DAB band (DAB 1, DAB 2 and DAB 3) changes.
- AM : Selects AM tuner.
- CH : Selects CD changer.*
- AUX : Selects the external components.
- Each time you press the button, “AUX INPUT” and “LINE INPUT” are alternately selected.
- 3 Changes the angle of the control panel to four positions.
- 4 Selects the sound modes.
- Each time you press the button, sound modes change.

- 5 • Searches for stations while listening to the radio.
- Selects ensembles while listening to the DAB tuner if pressed briefly.
- Selects services while listening to the DAB tuner if pressed and held.
- Fast-forwards or reverses the track/file if pressed and held while listening to any disc.
- Skips to the beginning of the next track/file or goes back to the beginning of the current (or previous) track/file if pressed briefly while listening to any disc. (See pages 18 and 23.)
- 6 • Changes the preset channel number while listening to the radio (or the DAB tuner).
- Each time you press the button, the preset channel number changes, and the selected station (or service) is tuned into.
- Skips to the first file of the next directory or the first file of the previous directory if pressed and held while listening to an MP3 disc. (See page 24.)
- Skips to the first file of the next directory or the first file of the previous directory of the same hierarchy level if pressed briefly while listening to an MP3 disc. (See page 25.)
- 7 • Changes the disc number while listening to the CD changer.
- Each time you press the button, the disc number changes, and the selected disc starts playing.
- Skips to the first file of a directory of an upper hierarchy level or a lower hierarchy level if pressed briefly while listening to an MP3 disc. (See page 25.)
- 8 Skips to the root directory while listening to an MP3 disc. (See page 25.)
- 9** Selects the sound adjustment items.
- Each time you press the button, the items change.
- 10** • Changes the volume.
- Adjusts the sound mode (after SEL is pressed).

* Without connecting the DAB tuner or CD changer, you cannot select it as the source to play.

** These buttons do not function in the preferred setting mode adjustment.



Preparing the remote controller

Before using the remote controller:

- Aim the remote controller directly at the remote sensor on the main unit. Make sure there is no obstacle in between.

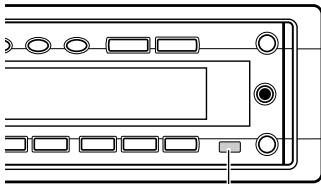

Remote sensor

- Do not expose the remote sensor to strong light (direct sunlight or artificial lighting).

Installing the battery

When the controllable range or effectiveness of the remote controller decreases, replace the battery.

1. Remove the battery holder.

- 1) Push out the battery holder in the direction indicated by the arrow using a ball-point pen or a similar tool.
- 2) Remove the battery holder.

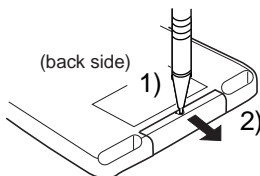

2. Place the battery.

Slide the battery into the holder with the + side facing upwards so that the battery is fixed in the holder.

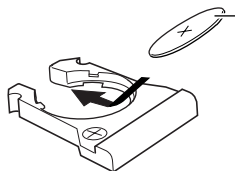

Lithium coin battery
(product number:
CR2025)

3. Return the battery holder.

Insert again the battery holder pushing it until you hear a clicking sound.

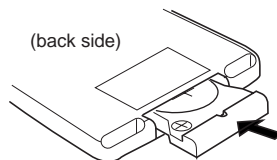

WARNING:

- Store the battery in a place where children cannot reach.
If a child accidentally swallows the battery, consult a doctor immediately.
- Do not recharge, short, disassemble or heat the battery or dispose it in a fire.
Doing any of these things may cause the battery to give off heat, crack or start a fire.
- Do not leave the battery with other metallic materials.
Doing this may cause the battery to give off heat, crack or start a fire.
- When throwing away or saving the battery, wrap it in tape and insulate; otherwise, the battery may start to give off heat, crack or start a fire.
- Do not poke the battery with tweezers or similar tools.
Doing this may cause the battery to give off heat, crack or start a fire.

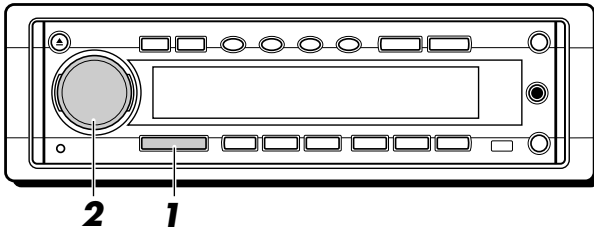

Note:

When you use this unit for the first time, set the built-in clock correctly, see page 30.

1 Turn on the power and select the source.

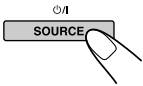

When you press the button for the first time, the power comes on. Then each time you press the button, the source changes as follows:

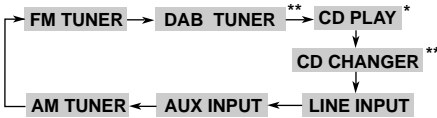

* If a disc is not in the loading slot, you cannot select CD as the source to play.

** Without connecting the DAB tuner or CD changer, you cannot select it as the source to play.

To operate the tuner (FM or AM), see pages 8 – 10.

To play a CD, see pages 17 – 19.

To play an MP3 disc, see pages 22 – 26.

To operate external components (AUX INPUT and LINE INPUT), see pages 37 – 38.

To operate the CD changer, see pages 39 – 40.

To operate the DAB tuner, see pages 41 – 44.

2 Adjust the volume.

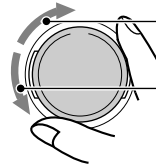

To increase the volume.

To decrease the volume.

Volume level appears.

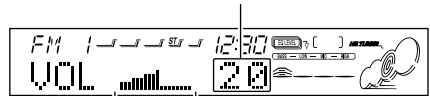

Volume level indicator

Note:

After adjusting the volume, you can push in the control dial to avoid unintended operations.

To use it again, push the control dial again to make it come out.

3 Adjust the sound as you want. (See page 27.)

To drop the volume in a moment

Press and hold /ATT while listening to any source. “ATT” starts flashing on the display, and the volume level will drop in a moment.

To resume the previous volume level, press and hold the button again.

- If you turn the control dial clockwise, you can also restore the sound.

To turn off the power

Press and hold SOURCE until “SEE YOU” appears on the display.

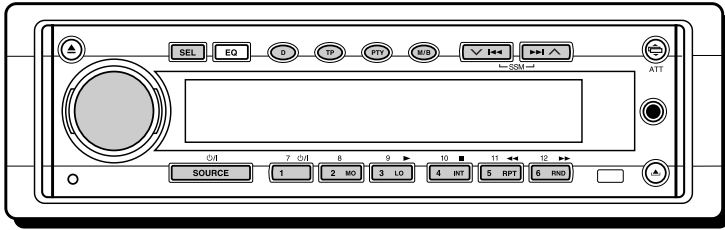

Listening to the radio

You can use either automatic searching or manual searching to tune into a particular station.

Searching a station automatically: Auto search

1 Select FM or AM.

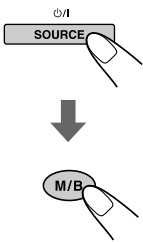

- 1 Press SOURCE $\phi/1$ repeatedly to select FM or AM as the source.
- 2 If necessary, press and hold M/B (mode/band) for more than 1 second repeatedly to select the FM band number. Each time you press and hold the button, the FM band changes as follows:



Selected band appears.

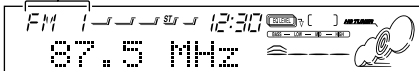

Note:

This receiver has three FM bands (FM1, FM2, FM3). You can use any one of them to listen to an FM broadcast.

2 Start searching a station.

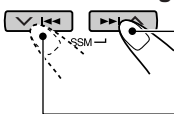

Press $\blacktriangleright \blacktriangleright \blacktriangleright$ to search stations of higher frequencies.

Press $\blacktriangleleft \blacktriangleleft \blacktriangleleft$ to search stations of lower frequencies.

To stop searching before a station is received, press the same button you have pressed for searching.

To tune into FM stations only with strong signals

- 1 Press M/B (mode/band) to enter the functions mode while listening to an FM broadcast.
- 2 Press LO (local) while still in the functions mode, so that the LOCAL indicator lights up on the display.
This function works only while searching FM stations, including SSM preset. Each time you press the button, the LOCAL indicator lights up and goes off alternately.

Searching a station manually: Manual search

1 Select FM or AM.

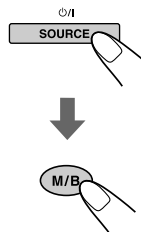

- 1 Press SOURCE $\phi/1$ repeatedly to select FM or AM as the source.
- 2 If necessary, press and hold M/B (mode/band) for more than 1 second repeatedly to select the FM band number. Each time you press and hold the button, the FM band changes as follows:



Note:

This receiver has three FM bands (FM1, FM2, FM3). You can use any one of them to listen to an FM broadcast.

When a station is received, searching stops.

2 Press and hold **▶▶| ^** or **∨|◀◀** until “M” (manual) starts flashing on the display.

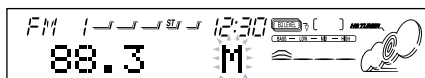
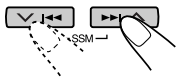

3 Tune into a station you want while “M” is flashing.

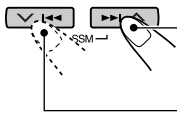

Press **▶▶| ^** to tune into stations of higher frequencies.

Press **∨|◀◀** to tune into stations of lower frequencies.

- If you release your finger from the button, the manual mode will automatically turn off after 5 seconds.
- If you hold down the button, the frequency keeps changing until you release the button.

Storing stations in memory

You can use one of the following two methods to store broadcasting stations in memory.

- Automatic preset of FM stations: SSM (Strong-station Sequential Memory)
- Manual preset of both FM and AM stations

FM station automatic preset: SSM

You can preset 6 local FM stations in each FM band (FM1, FM2 and FM3).

1 Select the FM band (FM1 – 3) you want to store FM stations into.

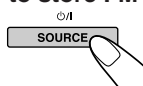

1 Press **SOURCE** repeatedly to select FM.

2 If necessary, press and hold **M/B** (mode/band) for more than 1 second repeatedly to select the FM band. Each time you press and hold the button, the FM band changes as follows:

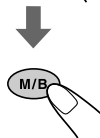

2 Press and hold both buttons for more than 2 seconds.

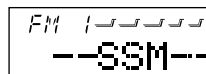
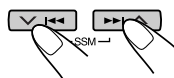

“SSM” appears, then disappears when automatic preset is over.

Local FM stations with the strongest signals are searched and stored automatically in the band number you have selected (FM1, FM2 or FM3). These stations are preset in the number buttons — No.1 (lowest frequency) to No.6 (highest frequency).

When automatic preset is over, the station stored in number button 1 will be automatically tuned into.

When an FM stereo broadcast is hard to receive:

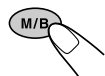

1 Press **M/B** (mode/band) to enter the functions mode while listening to an FM stereo broadcast.

2 Press **MO** (monaural) while still in the functions mode, so that the MO indicator lights up on the display.

- Each time you press the button, the MO and ST (stereo) indicators light up alternately.

Lights up when receiving an FM broadcast in stereo.

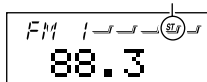

The MO indicator lights up.

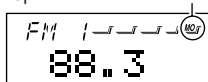

When the MO indicator is lit on the display, the sound you hear becomes monaural but the reception will be improved (the ST indicator goes off).



Manual preset

You can preset up to 6 stations in each band (FM1, FM2, FM3 and AM) manually.

Ex.: Storing an FM station of 88.3 MHz into the preset number 1 of the FM1 band

1 Select the band (FM1 – 3, AM) you want to store stations into (in this example, FM1).

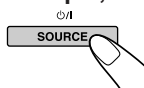

1 Press SOURCE $\phi/1$ repeatedly to select FM as the source.

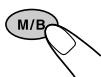

2 If necessary, press and hold M/B (mode/band) for more than 1 second repeatedly to select FM1. Each time you press and hold the button, the FM band changes as follows:



2 Tune into a station of 88.3 MHz.

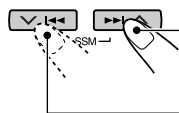

Press $\ggg \uparrow$ to tune into stations of higher frequencies.

Press $\ggg \downarrow$ to tune into stations of lower frequencies.

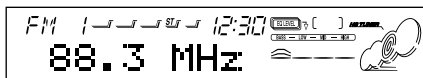

3 Press and hold the number button (in this example, 1) for more than 2 seconds.

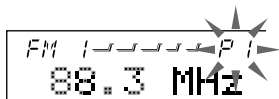

"P1" flashes for a while.

4 Repeat the above procedure to store other stations into other preset numbers.

Notes:

- A previously preset station is erased when a new station is stored in the same preset number.
- Preset stations are erased when the power supply to the memory circuit is interrupted (for example, during battery replacement). If this occurs, preset the stations again.

Tuning into a preset station

You can easily tune into a preset station. Remember that you must store stations first. If you have not stored them yet, see "Storing stations in memory" on page 9.

1 Select the band (FM1 – 3, AM).

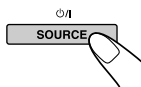

1 Press SOURCE $\phi/1$ repeatedly to select FM or AM as the source.

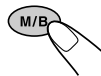

2 If necessary, press M/B (mode/band) for more than 1 second repeatedly to select the FM band number. Each time you press and hold the button, the FM band changes as follows:



2 Select the number (1 – 6) for the preset station you want.

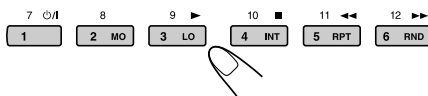

If the sound quality decreases and the stereo effect is lost while listening to an FM station...

In some areas, adjacent stations may interfere with each other. If such interference occurs, this unit can automatically reduce the interference noise (the initial setting when shipped from the factory). However, in this case, the sound quality will be degraded and the stereo effect will also be lost.

If you do not want to degrade the sound quality and to lose the stereo effect, rather than to eliminate the interference noise, see "To change the FM tuner selectivity – IF FILTER" on page 33.



What you can do with RDS EON

RDS (Radio Data System) allows FM stations to send an additional signal along with their regular programme signals. For example, the stations send their station names, as well as information about what type of programme they broadcast, such as sports or music, etc.

Another advantage of RDS function is called “EON (Enhanced Other Networks).” The EON indicator lights up while receiving an FM station with the EON data. By using the EON data sent from a station, you can tune into a different station of a different network broadcasting your favorite programme or traffic announcement while listening to another programme or to another source such as CD.

By receiving the RDS data, this unit can do the following:

- Tracing the same programme automatically (Network-Tracking Reception)
- Standby Reception of TA (Traffic Announcement) or your favorite programme
- PTY (Programme Type) search
- Programme search
- And some other functions

Tracing the same programme automatically (Network-Tracking Reception)

When driving in an area where FM reception is not good, the tuner built in this unit automatically tunes into another RDS station, broadcasting the same programme with stronger signals. So, you can continue to listen to the same programme in its finest reception, no matter where you drive. (See the illustration on the next page.)

Two types of the RDS data are used to make Network-Tracking Reception work correctly — PI (Programme Identification) and AF (Alternative Frequency).

Without receiving these data correctly from the RDS station you are listening to, Network-Tracking Reception will not operate.

To use **Network-Tracking Reception**, press and hold TP (traffic programme) for more than 1 second. Each time you press and hold the button, Network-Tracking Reception modes change as follows:

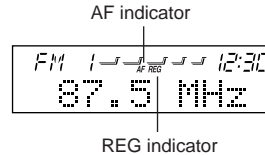
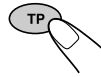

○: lights ✕: goes off

	AF indicator	REG indicator
Mode 1	○	✕
Mode 2	○	○
Mode 3	✕	✕

Mode 1

Network-Tracking Reception is activated with Regionalization set to “off.”

Switches to another station within the same network when the receiving signals from the current station become weak.

- *In this mode, the programme may differ from the one currently received.*

Mode 2

Network-Tracking Reception is activated with Regionalization set to “on.”

Switches to another station, within the same network, broadcasting the same programme when the receiving signals from the current station become weak.

Mode 3

Network-Tracking Reception is deactivated.

Note:

If a DAB tuner is connected and Alternative Reception (for DAB services) is activated, Network-Tracking Reception is also activated automatically. On the other hand, Networking-Tracking Reception cannot be deactivated without deactivating Alternative Reception. (See page 44.)



The same programme can be received on different frequencies.

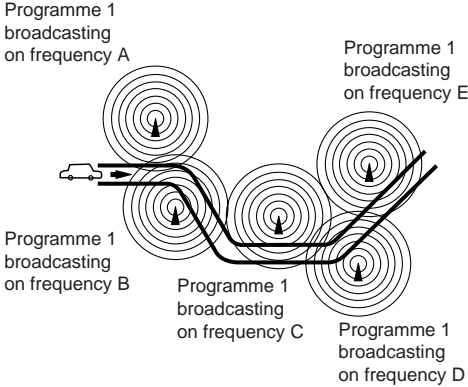

Using Standby Reception

Standby Reception allows the unit to switch temporarily to your favorite programme (PTY: Programme Type) and Traffic Announcement (TA) from the current source (another FM station, CD or other connected components).

- Standby Reception will not work if you are listening to an AM station.

TA Standby Reception

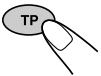

When you press TP while listening to an FM station, the TP indicator is lit during reception of a TP (Traffic Programme) station and the TA standby mode is engaged.

- When the station being received is not a TP station, the TP indicator flashes. Press **▶▶|** **▲** or **▼** **|◀◀** to engage the TA standby mode. "SEARCH" appears on the display, and TP station search starts. When a TP station is tuned into, the TP indicator is lit.
- If you are listening to a CD or other connected components and wish to listen to a TP station, press TP to enter the TA standby mode. (The TP indicator lights up.)

If a traffic programme starts broadcasting while the TA standby mode is active, "TRAFFIC" appears and the playback source changes to the FM band. The volume increases to the preset TA volume level (see page 15) and the traffic programme can be heard.

To deactivate the TA standby mode, press TP again.

PTY Standby Reception



When you press PTY while listening to an FM station, the PTY indicator is lit during reception of a PTY station and the PTY standby mode is engaged. The selected PTY name stored on page 13 flashes for 5 seconds.

- When the station being received is not a PTY station, the PTY indicator flashes. Press **▶▶|** **▲** or **▼** **|◀◀** to engage the PTY standby mode. "SEARCH" appears on the display, and PTY station search starts. When a PTY station is tuned into, the PTY indicator is lit.
- If you are listening to a CD or other connected components and wish to listen to a selected PTY broadcast, press PTY to enter the PTY standby mode. (The PTY indicator lights up.)

If the selected PTY programme starts broadcasting while the PTY standby mode is active, the selected PTY name appears and the playback source changes to the FM band. The selected PTY programme can then be heard.

To deactivate the PTY standby mode, press PTY again.



Selecting your favorite programme for PTY Standby Reception

You can select your favorite programme for PTY Standby Reception to store in memory.

When shipped from the factory, "NEWS" is stored as the programme type for PTY Standby Reception.

- 1 Press and hold SEL (select) for more than 2 seconds so that one of the PSM items appears on the display. (PSM: see page 31.)**



- 2 Select "PTY STBY" (standby) if not shown on the display.**

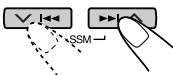

- 3 Select one of twenty-nine PTY codes. (See page 16.)**

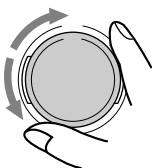

Selected code name appears on the display and is stored into memory.

- 4 Press SEL (select) to finish the setting.**



Searching your favorite programme

You can search one of your 6 favorite programme types stored in memory.

When shipped from the factory, the following 6 programme types have been stored in the number buttons (1 to 6).

To store your favorite programme types, see below.

To search your favorite programme type, see page 14.

1	2	3
POP M	ROCK M	EASY M
4	5	6
CLASSICS	AFFAIRS	VARIED

To store your favorite programme types

- 1 Press and hold SEL (select) for more than 2 seconds so that one of the PSM items appears on the display. (PSM: see page 31.)**



- 2 Select "PTY SEARCH" if not shown on the display.**

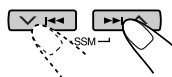

- 3 Select one of twenty-nine PTY codes. (See page 16.)**

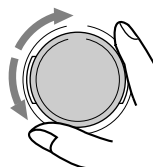

Selected code name appears on the display.

- If the code already stored in memory is selected, it will flash on the display.



4 Press and hold the number button for more than 2 seconds to store the PTY code selected into the preset number you want.

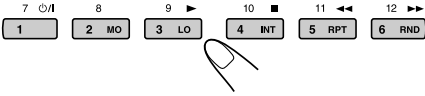

“MEMORY” and the selected code name will flash alternately. Then, only the selected code name will continue flashing on the display.

5 Press SEL (select) to finish the setting.



To search your favorite programme type

1 Press and hold PTY (programme type) for more than 1 second while listening to an FM station.

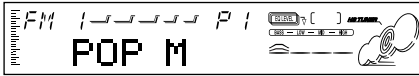
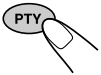

The last selected PTY code appears.

2 Select one of the PTY codes stored in the preset number buttons (1 to 6).

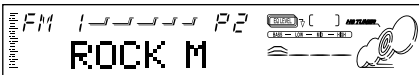
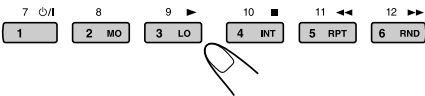

Ex.: When “ROCK M” is stored in preset number button 2

PTY search for your favorite programme starts after 5 seconds.

- If there is a station broadcasting a programme of the same PTY code as you selected, that station is tuned into.
- If there is no station broadcasting a programme of the same PTY code as you selected, the station will not change.

Note:

In some areas, the PTY search will not work correctly.

Other convenient RDS functions and adjustments

Automatic selection of the station when using the number buttons

Usually when you press the number button, the preset station is tuned into.

However, when the preset station is an RDS station, something different will happen. If the signals from that preset station are not sufficient for good reception, this unit, using the AF data, tunes into another frequency broadcasting the same programme as the original preset station is broadcasting. (Programme search)

- The unit takes some time to tune into another station using programme search.

To activate programme search, follow the procedure below.

- See also “Changing the general settings (PSM)” on page 30.

- 1 Press and hold SEL (select) for more than 2 seconds so that one of the PSM items appears on the display.
- 2 Press **▶▶** **▲** or **▼** **◀◀** to select “P-SEARCH.”
- 3 Turn the control dial clockwise to select “SEARCH ON.”
Now programme search is activated.
- 4 Press SEL (select) to finish the setting.

To cancel programme search, repeat the same procedure and select “SEARCH OFF” in step 3 by turning the control dial counterclockwise.



Changing the display mode while listening to an FM station

You can change the initial indication on the display to station name (PS NAME) or station frequency (FREQUENCY) while listening to an FM RDS station.

- See also “Changing the general settings (PSM)” on page 30.
- 1 Press and hold SEL (select) for more than 2 seconds so that one of the PSM items appears on the display.
 - 2 Press ►►| ▲ or ▼ |◄◄ to select “TUNER DISP” (tuner display).
 - 3 Turn the control dial to set to the desired indication (“FREQUENCY” or “PS NAME”).
 - 4 Press SEL (select) to finish the setting.

Note:

By pressing D (display), you can change the display while listening to an FM RDS station only.

Each time you press the button, the following information appears on the display:

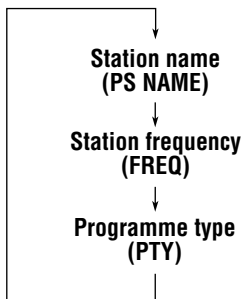

- Then, the display goes back to the original indication in several seconds.

Setting the TA volume level

You can preset the volume level for TA Standby Reception. When a traffic programme is received, the volume level automatically changes to the preset level.

- See also “Changing the general settings (PSM)” on page 30.
- 1 Press and hold SEL (select) for more than 2 seconds so that one of the PSM items appears on the display.
 - 2 Press ►►| ▲ or ▼ |◄◄ to select “TA VOL.”
 - 3 Turn the control dial to set to the desired volume. You can set it from “TA VOL 00” to “TA VOL 50.”
 - 4 Press SEL (select) to finish the setting.

Automatic clock adjustment

When shipped from the factory, the clock built in this unit is set to be readjusted automatically using the CT (Clock Time) data in the RDS signal.

If you do not want to use automatic clock adjustment, follow the procedure below.

- See also “Changing the general settings (PSM)” on page 30.
- 1 Press and hold SEL (select) for more than 2 seconds so that one of the PSM items appears on the display.
 - 2 Press ►►| ▲ or ▼ |◄◄ to select “AUTO ADJ.”
 - 3 Turn the control dial counterclockwise to select “ADJUST OFF.”
Now automatic clock adjustment is canceled.
 - 4 Press SEL (select) to finish the setting.

To reactivate clock adjustment, repeat the same procedure and select “ADJUST ON” in step 3 by turning the control dial clockwise.

Note:

You must stay tuned to the same station for more than 2 minutes after setting “AUTO ADJ” to “ADJUST ON.” Otherwise, the clock time will not be adjusted. (This is because the unit takes up to 2 minutes to capture the CT data in the RDS signal.)

**PTY codes**

NEWS:	News	SOCIAL:	Programmes on social activities
AFFAIRS:	Topical programmes expanding on current news or affairs	RELIGION:	Programmes dealing with any aspect of belief or faith, or the nature of existence or ethics
INFO:	Programmes which impart advice on a wide variety of topics	PHONE IN:	Programmes where people can express their views either by phone or in a public forum
SPORT:	Sport events	TRAVEL:	Programmes about travel destinations, package tours, and travel ideas and opportunities
EDUCATE:	Educational programmes	LEISURE:	Programmes concerned with recreational activities such as gardening, cooking, fishing, etc.
DRAMA:	Radio plays	JAZZ:	Jazz music
CULTURE:	Programmes on national or regional culture	COUNTRY:	Country music
SCIENCE:	Programmes on natural science and technology	NATION M:	Current popular music from another nation or region, in that country's language
VARIED:	Other programmes like comedies or ceremonies	OLDIES:	Classic pop music
POP M:	Pop music	FOLK M:	Folk music
ROCK M:	Rock music	DOCUMENT:	Programmes dealing with factual matters, presented in an investigative style
EASY M:	Easy-listening music		
LIGHT M:	Light music		
CLASSICS:	Classical music		
OTHER M:	Other music		
WEATHER:	Weather information		
FINANCE:	Reports on commerce, trading, the Stock Market, etc.		
CHILDREN:	Entertainment programmes for children		

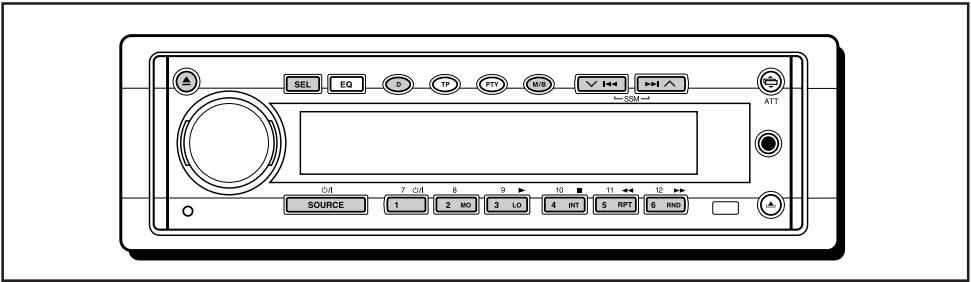

When playing an MP3 disc, refer also to “MP3 OPERATIONS” on pages 22 to 26.

Playing a CD

1 Open the loading slot.

The control panel moves down, and the loading slot appears.



Note:
When an external component is connected to the auxiliary input jack, be careful of handling a disc.

2 Insert a disc into the loading slot.

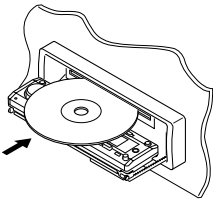

The unit draws the disc, the control panel goes back to the previous position (see page 35), and CD play starts automatically.

- All the tracks on the disc will be played repeatedly until you stop playback—All Track Repeat Play.

Note:
Do not insert any 8 cm disc into the loading slot as it will get stuck inside.

The display changes to show the following:

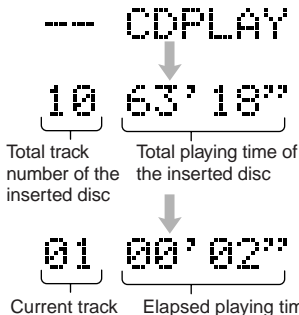

Notes:

- When a disc is in the loading slot, selecting “CD” as the source by pressing SOURCE starts CD play.
- When a disc is inserted upside down, the disc automatically ejects.
- When you play a CD Text, the disc title and performer appear on the display. Then the current track title appears on the display, followed by the track number and elapsed playing time. See also “Playing a CD Text” (page 19) and “To select the scroll mode – SCROLL” (page 32).
If a CD Text includes too much text information, some may not appear on the display.
- If you change the source, CD play also stops (without ejecting the disc).

To stop play and eject the disc

Press .

CD play stops, the control panel moves down, and the disc automatically ejects from the loading slot.

To return the control panel to its previous position, press again.

- If you keep the loading slot open for one minute (or 30 seconds when you have ejected a disc with the ignition key turned to “OFF”), a beep sounds and the control panel returns to its previous position.

Be careful not to get the disc or your finger caught in between the control panel and the unit.

Note:

If the ejected disc is not removed within 15 seconds, the disc is automatically inserted again into the loading slot to protect it from dust. (CD play will not start this time.)



Locating a track or particular portion on a CD

To fast-forward or reverse the track

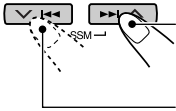

Press and hold **▶▶** **▲** while playing a disc, to fast-forward the track. Press and hold **▼** **◀◀** while playing a disc, to reverse the track.

To go to the next track or the previous tracks

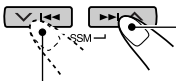

Press **▶▶** **▲** briefly while playing a disc, to go ahead to the beginning of the next track. Each time you press the button consecutively, the beginning of the next track is located and played back.

Press **▼** **◀◀** briefly while playing a disc, to go back to the beginning of the current track. Each time you press the button consecutively, the beginning of the previous tracks is located and played back.

To go to a particular track directly

Press the number button corresponding to the track number to start its playback.

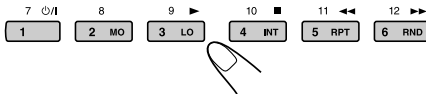

- To select a track number from 1 – 6: Press 1 (7) – 6 (12) briefly.
- To select a track number from 7 – 12: Press and hold 1 (7) – 6 (12) for more than 1 second.

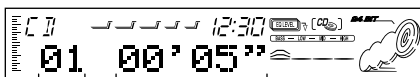

Track number Elapsed playing time

Selecting CD playback modes

To play back tracks at random (Random Play)

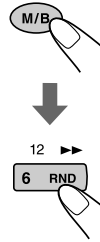

- 1 Press M/B (mode/band) while playing a disc. This unit enters the functions mode.
- 2 Press RND (random) while still in the functions mode, so that the RND indicator lights up on the display. Then, each time you press RND, random play mode turns on and off alternately.

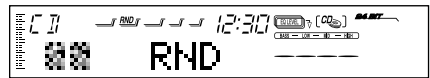

When the random mode is turned on, the RND indicator lights up on the display and a track randomly selected starts playing.

To play back the current track repeatedly (One Track Repeat Play)

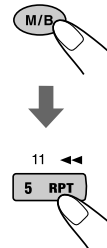

- 1 Press M/B (mode/band) while playing a disc. The unit enters the functions mode.
- 2 Press RPT (repeat) while still in the functions mode, so that the RPT indicator lights up on the display. Then, each time you press RPT, One Track Repeat Play turns on and off alternately.
 - When One Track Repeat Play is turned off, All Track Repeat Play is activated.

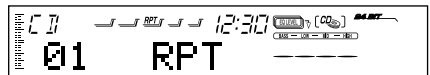



To play back only intros (Intro scan)

You can play back the first 15 seconds of each track sequentially.

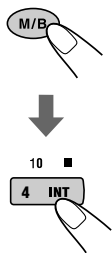

- 1 Press M/B (mode/band) while playing a disc. This unit enters the functions mode.
- 2 Press INT (intro scan) while still in the functions mode, so that the "INT" appears on the display. Then, each time you press INT, intro scan play mode turns on and off alternately.

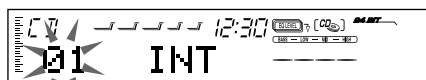

Track number of the currently playing track

Playing a CD Text

In a CD Text, some information about the disc (its disc title, performer and track title) is recorded. You can show these disc information on the display.

1 Select text display mode while playing a CD Text.



Each time you press the button, the display changes as follows:



Notes:

- The display shows up to 10 characters at one time and scrolls if there are more than 10 characters. See also "To select the scroll mode – SCROLL" on page 32.
- When you press D (display) while playing a conventional CD, "NO NAME" appears for the disc title/performer and the track title.

Prohibiting disc ejection

You can prohibit disc ejection and can lock a disc in the loading slot.

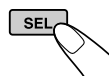

While pressing SEL (select), press and hold ▲ for more than 2 seconds.



"NO EJECT" flashes on the display for about 5 seconds, and the disc is locked and cannot be ejected.



Note:

If you press ▲ while disc ejection is prohibited, the control panel moves down, but the disc cannot be ejected.

To return the display panel to its previous position, press ▲.

To cancel the prohibition and unlock the disc, press and hold ▲ for more than 2 seconds again, while pressing SEL.

"EJECT OK" flashes on the display for about 5 seconds, and the disc is unlocked.



MP3 INTRODUCTION

What is MP3?

MP3 is an abbreviation of Motion Picture Experts Group (or MPEG) Audio Layer 3. MP3 is simply a file format with a data compression ratio of 1:10 (128 Kbps*). That means, by using MP3 format, one CD-R or CD-RW can contain 10 times as much data volume as a regular CD can.

* Bit rate is the average number of bits that one second of audio data will consume. The unit used is Kbps (1000 bits/second). To get a better audio quality, choose a higher bit rate. The most popular bit rate for encoding is 128 Kbps.

This unit is incorporated with an MP3 decoder. You can play back MP3 files (tracks) recorded on CD-Rs, CD-RWs, and CD-ROMs.

Compatible with ID3v1

Extra information data such as album title, performer name, song title, recording year, music genre and a brief comment can be stored within an MP3 file.

This unit can show ID3v1 tags (album name, performer name and song title) on the display. (See page 45.)

- Some characters cannot be shown correctly.
- This unit is not compatible with ID3v2.

Other Main Features in this unit:

- Maximum number of hierarchy levels: 8
- Maximum number of directories/files: 255 (Total)
- Available characters for directory/file names: A-Z, 0-9, _ (underscore)
- Maximum number of characters for file name (ISO 9660 Level 1): 12 (inclusive of separation mark—"." and extension code—"mp3")
- (ISO 9660 Level 2): 31 (inclusive of separation mark—"." and extension code—"mp3")
- Maximum number of characters for directory name: 31

Precautions when recording MP3 files on a CD-R or CD-RW

This unit can only read MP3 files that are recorded in the format that is compliant with ISO 9660 Level 1 or Level 2.

How are MP3 files recorded and played back?

MP3 "files (tracks)" can be recorded in "directories (folders)"—in PC terminology. During recording, the files and directories can be arranged in a way similar to arranging files and directories/folders of computer data.

"Root" is similar to the root of a tree. Every file and directory can be linked to and be accessed from the root.

In compliance with ISO 9660, the maximum allowable depth of nested directories—so-called "hierarchy"—is eight (inclusive of the root directory).

Playback order, file search order, and directory search order of the MP3 files recorded on a disc are determined by the writing (or encoding) application; therefore, playback order may be different from the one you have intended while recording the directories and the files.

The illustration on the next page shows an example of how MP3 files are recorded on a CD-R or CD-RW, how they are played back, and how they are searched on this unit.

Notes:

- The unit can read a CD-ROM containing MP3 files. However, if non-MP3 files are recorded together with MP3 files, this unit will take a longer time to scan the disc. It may also cause the unit to malfunction.
- The unit cannot read or play an MP3 file without the extension code—mp3.
- The unit is not compatible with Playlist**.

** A playlist is a simple text file, used on a PC, which enables users to make their own playback order without physically rearranging the files.



MP3 directory/file configuration

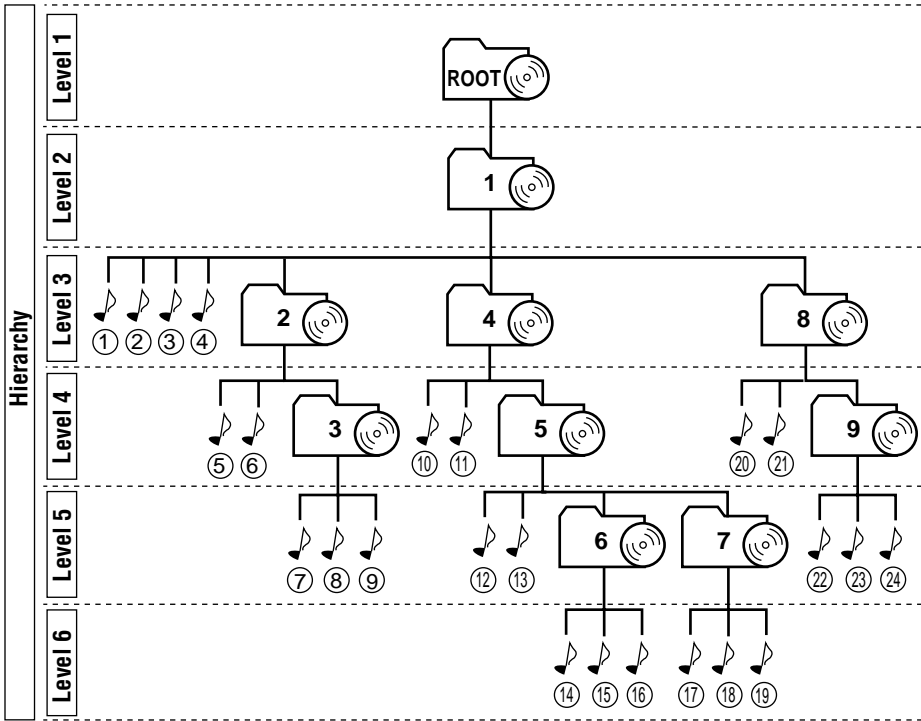

	: Root
	: Directories
	: MP3 files

Notes:

- In compliance with ISO 9660, the maximum number of hierarchy levels is eight, including the root directory.
- When a multi-session disc is loaded, you can only play back the contents of the last session.

MP3 playback/search order (page 23)

- The numbers in circles next to the MP3 files (🎵) indicate the playback order and search order of the MP3 files. Normally this unit plays back MP3 files in the recorded order.
- The numbers inside the directories indicate the playback order and search order of the directories on an MP3 disc. Normally this unit plays back MP3 files in the directories in the recorded order.

Movement between the directories (page 25)

You can move to another directory on the same hierarchy level (e.g. from Directory 3, you can go to Directory 5 or 9) or on a different hierarchy level (e.g. from Directory 5, you can go to Directory 4 or 6).

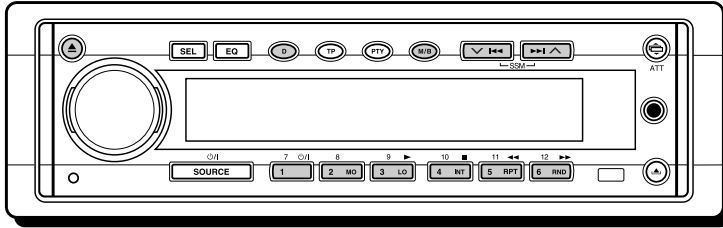

Refer also to “CD OPERATIONS” on pages 17 to 19.

Playing an MP3 disc

1 Open the loading slot.



The control panel moves down, and the loading slot appears.

2 Insert an MP3 disc into the loading slot.

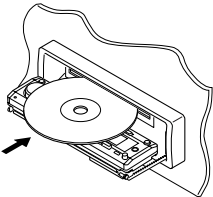

The unit draws the disc, the control panel goes back to its previous position (see page 35) and playback starts automatically.

Playback starts automatically from the first file of the first directory once file check is completed.

Then, the display changes to show the following:

- When “TAG ON” is selected (initial setting: see page 33)

Album name/performer name (directory name)* → Track title (file name)* → Elapsed playing time

* If an MP3 file does not have ID3 tags, directory name and file name appear.

- When “TAG OFF” is selected
Directory name and file name appear.

Notes:

- All the files on the disc will be played repeatedly until you stop playback—All File Repeat Play.
- MP3 discs require a longer readout time**. (It differs due to the complexity of the directory/file configuration.)

** Readout time is the time taken by the unit to scan or check the disc for files and file information.

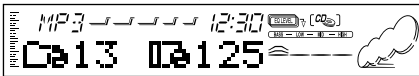

Ex.: When the disc contains 13 directories and 125 MP3 files.



To change the display information



While playing back an MP3 file, you can change the file information shown on the display.

Each time you press D (display), the display changes to show the following:

- When “TAG ON” is selected (initial setting: see page 33)

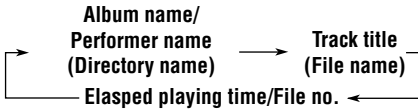

* If an MP3 file does not have ID3 tags, directory name and file name appear.

- When “TAG OFF” is selected

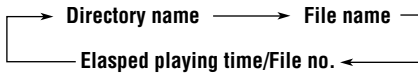

Note:

- The display shows up to 10 characters at one time and scrolls if there are more than 10 characters. See also “To select the scroll mode – SCROLL” on page 32.

To stop play and eject the disc

Press **▲**.

Playback stops, the control panel moves down, and the disc automatically ejects from the loading slot.

Locating a file or particular portion on an MP3 disc

To fast-forward or reverse the file

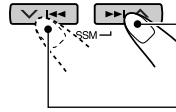

Press and hold **▶▶▶ ▲** while playing an MP3 disc, to fast-forward the file.

Press and hold **▼ ◀◀◀** while playing an MP3 disc, to reverse the file.

To skip to the next file or the previous files

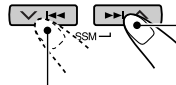

Press **▶▶▶ ▲** briefly while playing, to skip ahead to the beginning of the next file. Each time you press the button consecutively, the beginning of the next file is located and played back. (See “MP3 playback/search order” on page 21.)

Press **▼ ◀◀◀** briefly, while playing, to skip back to the beginning of the current file. Each time you press the button consecutively, the beginning of the previous files is located and played back. (See “MP3 playback/search order” on page 21.)

To go to a particular directory directly

IMPORTANT:

To directly select the directories using the number button(s), it is required that directories are assigned 2 digit numbers at the beginning of their directory names. (This can only be done during the recording of CD-Rs or CD-RWs.)

Ex.: If directory name is "01 ABC"

→ press 1 to go to directory "01 ABC"

If directory name is "1 ABC"

→ pressing 1 does not work

If directory name is "12 ABC"

→ press and hold 6 (12) to go to directory "12 ABC"

Press the number button corresponding to the directory number to start playing the first file in the selected directory.

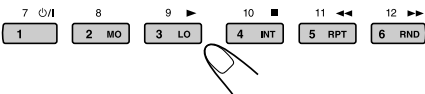

- To select a directory number from 01 – 06:
Press 1 (7) – 6 (12) briefly.
- To select a directory number from 07 – 12:
Press and hold 1 (7) – 6 (12) for more than 1 second.

Notes:

- If "MP3" flashes on the display after you have selected a directory, it means that the directory does not contain any MP3 files.
- You cannot directly select a directory with a number greater than 12.

To select a particular file in a directory, press **▶▶|▲** or **▼|◀◀** after selecting the directory.

To skip to the next directory—either on the same hierarchy level or on a different hierarchy level

On the control panel:

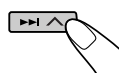

- 1 Press M/B (mode/band) while playing an MP3 disc. The unit enters the functions mode.
- 2 Press **▶▶|▲** briefly while still in the functions mode. Each time you repeat steps 1 and 2, the next directory is located (and the first file in the directory starts playing, if recorded). (See "MP3 playback/search order" on page 21.)

On the remote controller:



Each time you press and hold the button consecutively, the next directory is located (and the first file in the directory starts playing, if recorded). (See "MP3 playback/search order" on page 21.)

To skip to the previous directory—either on the same hierarchy level or on a different hierarchy level

On the control panel:

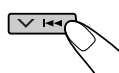

- 1 Press M/B (mode/band) while playing an MP3 disc. The unit enters the functions mode.
- 2 Press **▼|◀◀** briefly while still in the functions mode. Each time you repeat steps 1 and 2, the previous directory is located (and the first file in the directory starts playing, if recorded). (See "MP3 playback/search order" on page 21.)

On the remote controller:



Each time you press and hold the button consecutively, the previous directory is located (and the first file in the directory starts playing, if recorded). (See "MP3 playback/search order" on page 21.)

To skip to the next directory on the same hierarchy level

On the remote controller:



Each time you press the button consecutively, the next directory on the same hierarchy level is located (and the first file in the directory starts playing, if recorded).

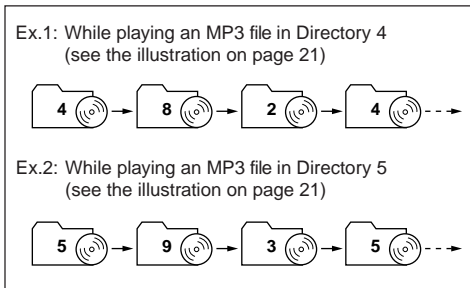

To skip to the directories on the lower hierarchy levels

On the remote controller:



Each time you press the button consecutively, a directory on the lower hierarchy level is located (and the first file in the directory starts playing, if recorded).

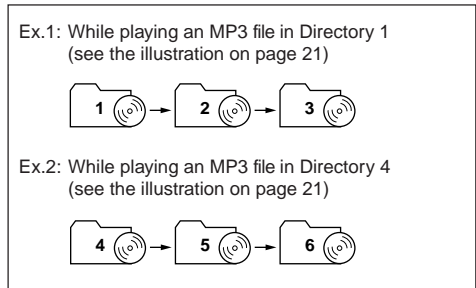

To skip to the previous directory on the same hierarchy level

On the remote controller:



Each time you press the button consecutively, the previous directory on the same hierarchy level is located (and the first file in the directory starts playing, if recorded).

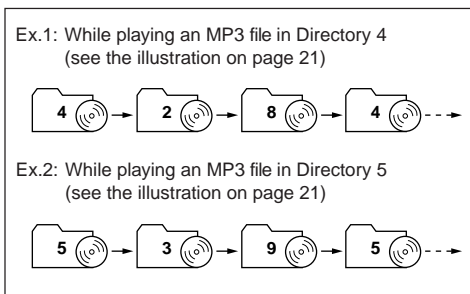

To skip to the directories on the upper hierarchy levels

On the remote controller:



Each time you press the button consecutively, a directory on the upper hierarchy level is located (and the first file in the directory starts playing, if recorded).

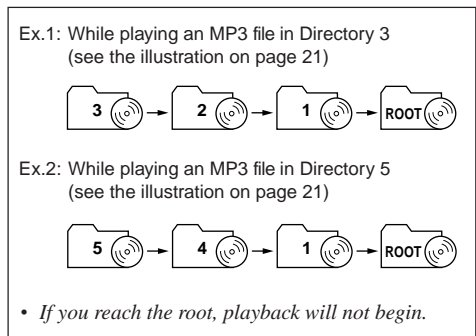

Note:

If there is no MP3 file in a directory that you have skipped to, its directory name appears on the display with "MP3" flashing. If this happens, the unit pauses automatically.

To go back to the root directly, press **R•D** on the remote controller. You can go back to the root from any directory.

- If files are recorded on the first hierarchy level without putting them into a directory, this unit starts playing the files.



Selecting MP3 playback modes

To play back files at random (Random Play)



- 1 Press M/B (mode/band) while playing an MP3 disc. The unit enters the functions mode.

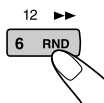

- 2 Press RND (random) while still in the functions mode, so that the RND indicator lights up on the display.

Then, each time you press RND, the random play mode turns on and off alternately.

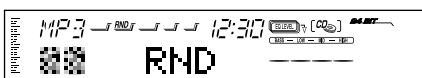

When the random mode is turned on, the RND indicator lights up on the display and a file randomly selected from all the files in the disc starts playing.

To play back only intros (Intro scan)

You can play back the first 15 seconds of each file sequentially.

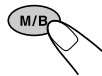

- 1 Press M/B (mode/band) while playing an MP3 disc. The unit enters the functions mode.

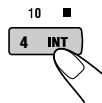

- 2 Press INT (intro scan) while still in the functions mode, so that "INT" appears on the display. Then, each time you press INT, the intro scan play mode turns on and off alternately.



File number of the currently playing file

To play back files repeatedly (Repeat Play)



- 1 Press M/B (mode/band) while playing an MP3 disc. The unit enters the functions mode.

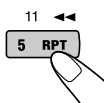

- 2 Press RPT (repeat) while still in the functions mode, so that the RPT indicator lights up on the display.

Then, each time you press RPT, the repeat play mode changes as follows:

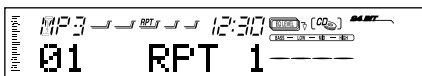

Ex.: When "RPT 1" is selected.

Mode	RPT Indicator	Plays repeatedly
RPT 1	Lights	The current file (or specified file).
RPT 2	Flashes	All files of the current directory (or specified directory).



Adjusting the sound

You can adjust the sound characteristics to your preference.

1 Select the item you want to adjust.



Each time you press the button, the adjustable items change as follows:

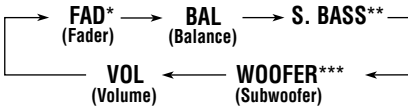

2 Adjust the level.

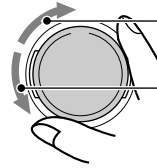

To increase the level.

To decrease the level.

Note:

Normally, the control dial works as the volume control. So you do not have to select "VOL" to adjust the volume level.

Indication	To do:	Range
FAD*	Adjust the front and rear speaker balance.	R06 (Rear only) F06 (Front only)
BAL	Adjust the left and right speaker balance.	L06 (Left only) R06 (Right only)
S. BASS**	Adjust the bass.	00 (min.) 08 (max.)
WOOFER***	Adjust the subwoofer output level.	00 (min.) 12 (max.)
VOL	Adjust the volume.	00 (min.) 50 (max.)

* If you are using a two-speaker system, set the fader level to "00."

** The richness and fullness of the bass sound is clearly maintained regardless of how low you set the volume – Super Bass.

*** This takes effect only when a subwoofer is connected.



Selecting preset sound modes

You can select a preset sound mode suitable to the music genre.

1 Press EQ.

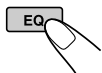

The last selected sound mode is recalled, and it is applied to the current source.

The EQ indicator lights up.

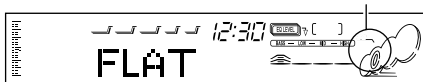

Ex.: When you have selected "FLAT" previously

2 Select the sound mode you want.

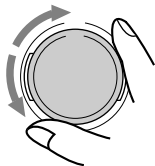

As you turn the control dial, the sound modes change as follows:

FLAT ⇄ Hard Rock ⇄ R & B* ⇄ POP ⇄
JAZZ ⇄ DanceMusic ⇄ Country ⇄ Reggae ⇄
Classic ⇄ USER 1 ⇄ USER 2 ⇄ USER 3 ⇄
(back to the beginning)

* Rhythm and Blues

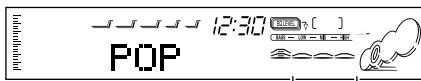

EQ level changes as you select the sound mode.

Ex.: When you select "POP"

To cancel the sound mode, select "FLAT" in step 2.

Notes:

- You can adjust each sound mode to your preference, and store it in memory.
If you want to adjust and store your original sound mode, see "Storing your own sound adjustments" on page 29.
- To adjust the bass reinforcement level temporarily, see page 27.

To store a sound mode separately for each playback source (EQ Link)

Once you select a sound mode, it is stored in memory. It will be recalled every time you select the same source.

A sound mode can be stored for each of the following sources — FM1, FM2, FM3, AM, CD and external components.

- See also "Changing the general settings (PSM)" on page 30.

- Press and hold SEL (select) for more than 2 seconds so that one of the PSM items appears on the display.
- Press \blacktriangleright \blacktriangle or \blacktriangleright \blacktriangleleft to select "EQ LINK" (Equalization Link).
- Turn the control dial clockwise to select "LINK ON."
- Press SEL (select) to finish the setting.

To cancel EQ Link, repeat the same procedure and select "LINK OFF" by turning the control dial counterclockwise in step 3.

- When "EQ LINK" is set to "LINK ON"**
The selected sound mode can be stored in memory for the current source.
Each time you change to the same source, the same sound mode is also recalled, and shown after the source name.
- When "EQ LINK" is set to "LINK OFF"**
The selected sound mode effect applies to all the sources selected.



Storing your own sound adjustments

You can adjust the sound modes to your preference and store your own adjustments in memory (USER 1, USER 2 and USER 3).

- There is a time limit in doing the following procedure. If the setting is canceled before you finish, start from step 1 again.

1 Press EQ.



The last selected sound mode is recalled, and is applied to the current source.

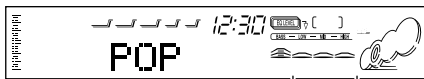

Ex.: When you have selected "POP" previously

2 Press SEL (select) to select sound elements to adjust.



Each time you press the button, the sound elements change as follows:

LOW FREQ.* → LOW WIDTH → LOW LEVEL →
 MID FREQ.* → MID WIDTH → MID LEVEL →
 HIGH FREQ.* → HIGH LEVEL →
 (back to the beginning)

FREQ. (LOW, MID, HIGH):

Select the center frequency to adjust.

WIDTH (LOW, MID):

Select the band width level (Q).

LEVEL (LOW, MID, HIGH):

Adjust the enhancement level.

* By pressing ►►► ▲ or ▼ ◀◀◀, you can directly move as follows:



3 Adjust the selected sound element.

- Refer to the table below for adjusting the selected sound element.

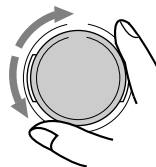

4 Repeat steps 2 and 3 to adjust the other sound elements.

5 Select one of the user sound modes (USER 1, USER 2, USER 3).

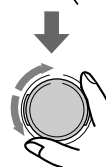
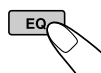

Ex.: When you select "USER 2"

6 Press EQ to store the adjustments.

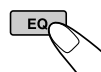

To reset to the factory settings

Repeat the same procedure and reassign the preset values listed in the table on page 45.

Indication	Preset values		
	LOW	MID	HIGH
FREQ.	50 Hz 80 Hz 120 Hz	700 Hz 1 kHz 2 kHz	8 kHz 12 kHz
WIDTH	1 (min.) 4 (max.)	1 (min.) 2 (max.)	_____
LEVEL	-06 (min.) +06 (max.)	-06 (min.) +06 (max.)	-06 (min.) +06 (max.)

Setting the clock

- 1 Press and hold SEL (select) for more than 2 seconds so that one of the PSM items appears on the display. (See page 31.)



- 2 Set the hour.

- 1 Select "CLOCK HOUR" if not shown on the display.
- 2 Adjust the hour.

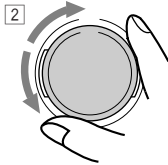
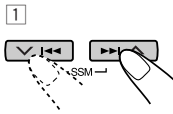

- 3 Set the minute.

- 1 Select "CLOCK MIN."
- 2 Adjust the minute.

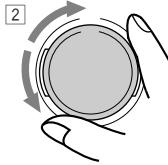
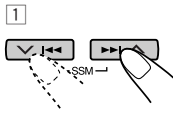

- 4 Select the clock system.

- 1 Select "24H/12H."
- 2 Select either "12HOUR" or "24HOUR."

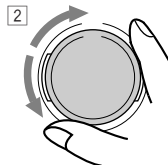
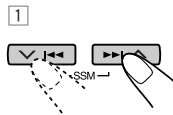

- 5 Press SEL (select) to finish the setting.



Changing the general settings (PSM)

You can change the items listed on the next page by using the PSM (Preferred Setting Mode) control.

Basic Procedure

- 1 Press and hold SEL (select) for more than 2 seconds so that one of the PSM items appears on the display. (See page 31.)



- 2 Select a PSM item you want to adjust. (See page 31.)

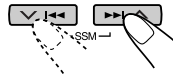

- 3 Adjust the PSM item selected.



- 4 Repeat steps 2 and 3 to adjust the other PSM items if necessary.

- 5 Press SEL (select) to finish the setting.



To check the current clock time while the unit is turned off, press D (display).

The power turns on, the clock time is shown for 5 seconds, then the power turns off.

Preferred Setting Mode (PSM) items

1 Hold.		2 Select.		3 Set. Counter-clockwise / Clockwise		Factory-preset settings	See page
CLOCK HOUR	Hour adjustment	Back	Advance	0:00	30		
CLOCK MIN	Minute adjustment	Back	Advance				
EQ LINK	Sound control memory linkage	LINK OFF	LINK ON	LINK OFF	28		
24H/12H	24/12-hour time display	12HOUR	24HOUR	24HOUR	30		
AUTO ADJ	Automatic clock setting	ADJUST OFF	ADJUST ON	ADJUST ON	15		
CLOCK DISP	Clock display	CLOCK OFF	CLOCK ON	CLOCK ON	32		
TUNER DISP	Tuner display	FREQUENCY	PS NAME	PS NAME	15		
PTY STBY	PTY standby	29 program types (See pages 13 and 16.)		NEWS	13		
PTY SEARCH	PTY search						
TA VOL	Traffic announcement volume	TA VOL 00 – TA VOL 50		TA VOL 20	15		
P-SEARCH	Programme search	SEARCH OFF	SEARCH ON	SEARCH OFF	14		
DAB AF*	Alternate frequency search	AF OFF	AF ON	AF ON	44		
LEVEL/EQ	Equalizer/Level indicator	EQ ONLY ↔ LEVEL+EQ LEVEL ONLY ↕		EQ ONLY	32		
DIMMER	Dimmer mode	AUTO ↔ OFF ↕ ON ↕		AUTO	32		
TELEPHONE	Telephone muting	MUTING OFF ↔ MUTING1 ↕ MUTING2 ↕		MUTING OFF	32		
BEEP SW	Key-touch tone	BEEP OFF	BEEP ON	BEEP ON	32		
P.AMP SW	Power amplifier switch	P.AMP OFF	P.AMP ON	P.AMP ON	32		
CONTRAST	Display contrast	CONTRAST 1 – CONTRAST 10		CONTRAST 5	32		
SCROLL	Scroll mode	ONCE ↔ AUTO ↕ OFF ↕		ONCE	32		
CUTOFF F	Subwoofer cutoff Frequency	FREQ MID ↔ FREQ HIGH ↕ FREQ LOW ↕		FREQ MID	33		
LINE ADJ	Line input level adjustment	L.ADJ 00 – L.ADJ 05		L.ADJ 00	33		
AUX ADJ	Auxiliary input level adjustment	A.ADJ 00 – A.ADJ 05		A.ADJ 00	33		
KEY SELECT	External key-operation mode selection	DVD ↔ VCR ↕ OFF ↕		DVD	33		
IF FILTER	Intermediate frequency filter	WIDE	AUTO	AUTO	33		
DEMO MODE	Demonstration mode	DEMO OFF	DEMO ON	DEMO ON	33		
TAG DISP	Tag display	TAG OFF	TAG ON	TAG ON	33		

• Press SEL (select) to finish the setting.

* Displayed only when the DAB tuner is connected.



To set the clock display – CLOCK DISP

You can set the clock to be shown on the display when the unit is turned on.

When shipped from the factory, the clock is set to be shown on the display.

- **CLOCK ON:** Clock display is turned on.
- **CLOCK OFF:** Clock display is turned off.

To select the level meter – LEVEL/EQ

You can select the level display according to your preference.

When shipped from the factory, this mode is set to “EQ ONLY.”

- **EQ ONLY:** Equalizer pattern is displayed.
- **LEVEL+EQ:** Equalizer pattern is displayed along with audio level meter.
- **LEVEL ONLY:** Audio Level meter illuminates upward and downward from center.

To select the dimmer mode – DIMMER

When you turn on the car head lights, the display automatically dims (Auto Dimmer).

When shipped from the factory, Auto Dimmer mode is activated.

- **AUTO:** Activates Auto Dimmer.
- **OFF:** Cancels Auto Dimmer.
- **ON:** Always dims the display.

Note:

Auto Dimmer equipped for this unit may not work correctly on some vehicles, particularly on those having a control dial for dimming.

In this case, set the dimmer mode to “ON” or “OFF.”

To select the telephone muting – TELEPHONE

This mode is used when a cellular phone system is connected. Depending on the phone system used, select either “MUTING 1” or “MUTING 2,” whichever mutes the sounds from this unit. When shipped from the factory, this mode is deactivated.

- **MUTING 1:** Select this if this setting can mute the sounds.
- **MUTING 2:** Select this if this setting can mute the sounds.
- **MUTING OFF:** Cancels the telephone muting.

To turn on/off the key-touch tone – BEEP SW

You can deactivate the key-touch tone if you do not want it to beep each time you press a button. When shipped from the factory, the key-touch tone is activated.

- **BEEP ON:** Activates the key-touch tone.
- **BEEP OFF:** Deactivates the key-touch tone.

To turn on/off the power amplifier switch – P. AMP SW

You can switch off the built-in amplifier and send the audio signals only to the external amplifier(s) to get clear sounds and to prevent internal heat buildup inside this unit.

When shipped from the factory, the power amplifier switch is turned on so that the built-in amplifier works.

- **P. AMP ON:** Select this mode when not using external amplifier(s).
- **P. AMP OFF:** Select this mode when using external amplifier(s).

To adjust the display contrast level – CONTRAST

You can adjust the display contrast level among 1 (dark) to 10 (bright). When shipped from the factory, the display contrast level is set at level 5.

To select the scroll mode – SCROLL

You can select the scroll mode for the disc information if it consists of more than 10 characters.

When shipped from the factory, Auto Scroll mode is set to “ONCE.”

- **ONCE:** Scrolls only once.
- **AUTO:** Repeats the scroll (5-second intervals in between).
- **OFF:** Cancels Auto Scroll.

Note:

Even if the scroll mode is set to “OFF,” you can scroll the display by pressing D (display) for more than 1 second.

To select the subwoofer cutoff frequency – CUTOFF F

When a subwoofer is connected to this unit, select an appropriate cutoff frequency level for your subwoofer.

When shipped from the factory, the subwoofer cutoff frequency is set to “FREQ MID.”

- **FREQ LOW:** Frequencies higher than 50 Hz are cut off to the subwoofer.
- **FREQ MID:** Frequencies higher than 80 Hz are cut off to the subwoofer.
- **FREQ HIGH:** Frequencies higher than 120 Hz are cut off to the subwoofer.

To adjust the line input level – LINE ADJ

Adjust the line input level properly when an external component is connected to the LINE IN plugs.

When shipped from the factory, the line input level is set at level 00.

If the input level of the connected component is not high enough, increase the input level properly. Without adjusting the line input level, you may be surprised at a loud sound when you change the source from the external component to another source.

To adjust the auxiliary input level – AUX ADJ

Adjust the auxiliary input level properly when an external component is connected to the Auxiliary input jack.

When shipped from the factory, the auxiliary input level is set at level 00.

If the input level of the connected component is not high enough, increase the input level properly. Without adjusting the line input level, you may be surprised at a loud sound when you change the source from the external component to another source.

To select the target component to operate through this receiver – KEY SELECT

You can operate either JVC’s DVD player or VCR through this receiver, by using the number buttons on the control panel.

When shipped from the factory, these number buttons are set to be used for the DVD operations.

To use these number buttons on the control panel for DVD or VCR operations, see page 37.

To change the FM tuner selectivity – IF FILTER

In some areas, adjacent stations may interfere with each other. If this interference occurs, noise may be heard. This unit has been preset to automatically reduce this interference noise (“AUTO”) when shipped from the factory.

- **AUTO:** When this type of interference occurs, this unit automatically increases the tuner selectivity so that interference noise will be reduced. (But the stereo effect will also be lost.)
- **WIDE:** Subject to the interference from adjacent stations, but sound quality will not be degraded and the stereo effect will not be lost.

To turn the demo mode on or off – DEMO MODE

You can turn the demo mode on or off. When shipped from the factory, “DEMO ON” is selected.

- **DEMO ON:** Turns the demo mode on. The demonstration will start automatically if no sound comes in for 3 minutes.
- **DEMO OFF:** Turns the demo mode off.

Note:

If the unit has been reset (and the power is on), demonstration will start if no sound comes in for about 10 seconds.

To turn the tag display on or off – TAG DISP

An MP3 file can contain file information called “ID3 Tag” where its album name, performer, track title, etc. are recorded.

There are two versions—ID3v1 (ID3 Tag version 1) and ID3v2 (ID3 Tag version 2). This unit is compatible only with ID3v1.

When shipped from the factory, “TAG ON” is selected.

- **TAG ON:** Turns on the ID3 tag display while playing MP3 files.
* If an MP3 file does not have ID3 tags, directory name and file name appear.

Note:

If you change the setting from “TAG OFF” to “TAG ON” while playing an MP3 file, the tag display will be activated when the next file starts playing.

- **TAG OFF:** Turns off the ID3 tag display while playing MP3 files. (Only the directory name and file name can be shown.)

Assigning names to the sources

You can assign names to CDs and the external components.

After assigning a name, it will appear on the display when you select the source.

Sources	Maximum number of the characters
CDs*	up to 32 characters (up to 40 discs)
External components (LINE INPUT and AUX INPUT)	up to 10 characters

* You cannot assign a name to a CD Text or an MP3 disc.

1 Select a source you want to assign a name to.

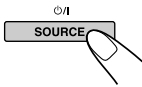

Each time you press the button, the source changes as described on page 7.

2 Press and hold SEL (select) for more than 2 seconds while pressing D (display).

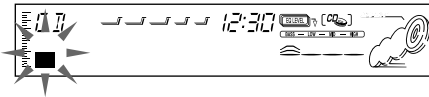
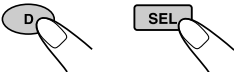

When you select "CD PLAY" as the source

3 Select the character set you want while "■" is flashing.



Each time you press the button, the character set changes as follows:

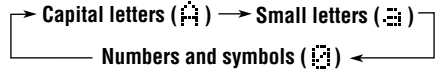

4 Select a character.



About the available characters, see page 45.

5 Move the cursor to the next (or previous) character position.

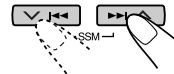

6 Repeat steps 3 to 5 until you finish inputting the name.

7 Finish the procedure while the last selected character is flashing.



To erase the input characters

Insert spaces using the same procedure described above.

Notes:

- When you try to assign a name to the 41st disc, "NAME FULL" appears on the display. (In this case, delete unwanted names before assignment.)
- When the CD changer is connected, you can assign names to discs in the CD changer. These names can also be shown on the display if you insert the discs in this unit.

Changing the control panel angle

You can change the angle of the control panel to four positions.

Adjust the angle to the position you want.



Each time you press the button, the panel angle changes as follows:

CAUTION:

NEVER insert your finger in between the control panel and the unit, as it may get caught or hurt.

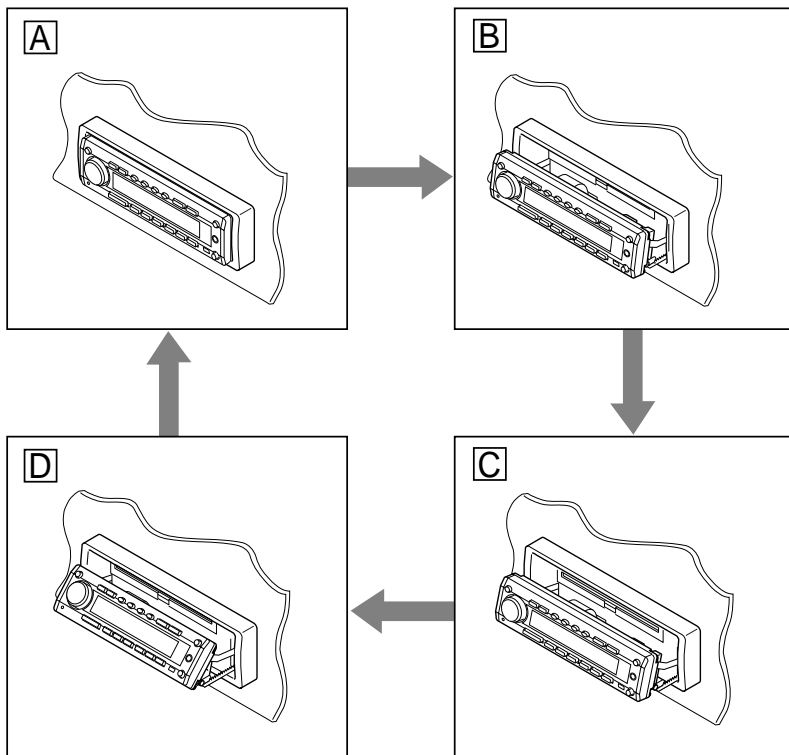
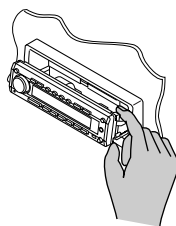

When using the remote controller

Press ANGLE ▼ repeatedly. Each time you press the button, the control panel changes its angle — [A], [B], [C], then [D] positions in sequence.

To restore the control panel to its original position,

Press ANGLE ▲ repeatedly. Each time you press the button, the control panel changes its angle in reverse — [D], [C], [B], then [A] positions in sequence.

Detaching the control panel

You can detach the control panel when leaving the car.

When detaching or attaching the control panel, be careful not to damage the connectors on the back of the control panel and on the panel holder.

Detaching the control panel

Before detaching the control panel:

- Be sure to turn off the power
- Be sure to return the control panel to its original position

1 Unlock the control panel.

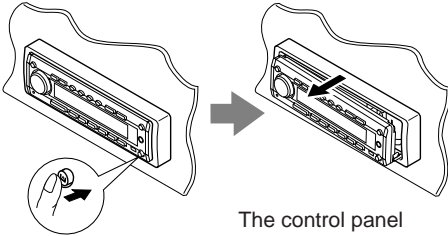

The control panel comes out toward you.

2 Move the control panel to the right, then pull it out of the unit.

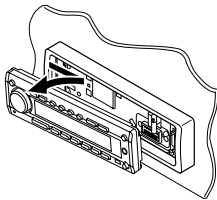

3 Put the detached control panel into the provided case.

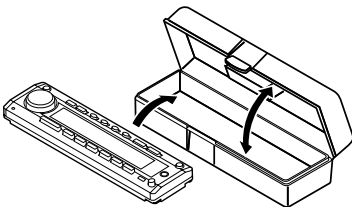

Attaching the control panel

1 Insert the left side of the control panel into the groove on the panel holder.

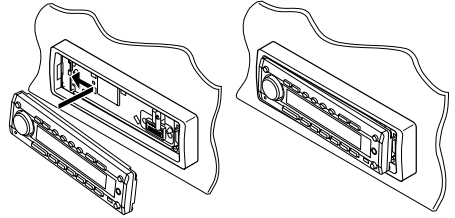

2 Press the right side of the control panel to fix it to the panel holder.

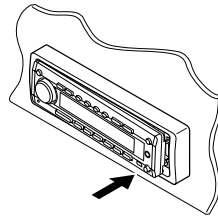

Note on cleaning the connectors:

If you frequently detach the control panel, the connectors will deteriorate.

To minimize this possibility, periodically wipe the connectors with a cotton swab or cloth moistened with alcohol, being careful not to damage the connectors.

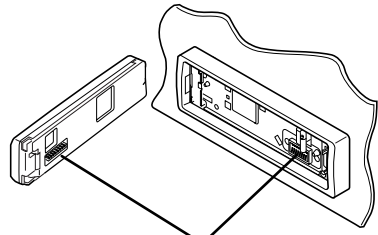

Connectors

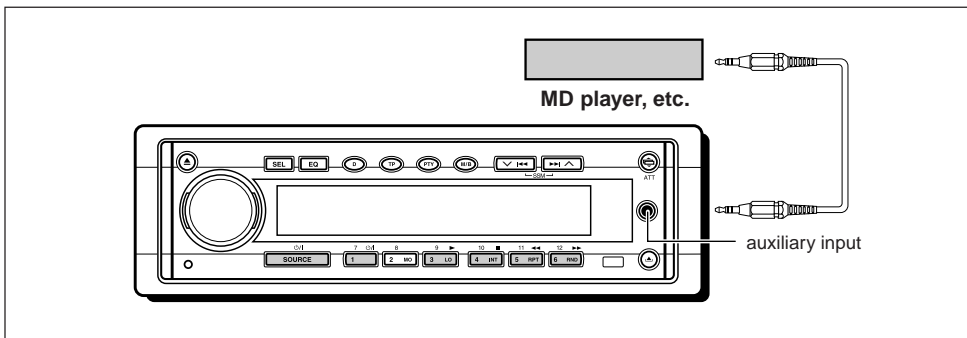

Playing external components

You can connect two external components to this unit.

Connect one to the auxiliary input jack on the control panel, and the other to the LINE IN plugs on the rear.

You can connect a JVC DVD player or VCR to the LINE IN plugs.

You can operate a JVC DVD player or VCR through this receiver using the number buttons on the control panel.

When you operate the VCR, you have to change the operation mode of the number buttons from the DVD operation mode to the VCR operation mode. (See "To select the target component to operate through this receiver – KEY SELECT" on page 33.)

If the input level of the external components is not high enough, increase the input level properly.

Without adjusting the input level, you may be surprised at a loud sound when you change the source from the external components to another. (See "To adjust the line input level – LINE ADJ" and "To adjust the auxiliary input level – AUX ADJ" on page 33.)

1 Select the external component (AUX INPUT or LINE INPUT).

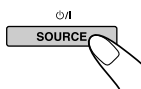

When you select a source, the power automatically comes on.

Each time you press the button, the source changes as described on page 7.



AUX INPUT: To select the component connected to the auxiliary input jack on the control panel



LINE INPUT: To select the component connected to the LINE IN plugs on the rear



2 Turn on the connected component and start playing the source.

- If connecting a JVC DVD player or VCR, you can perform the following operations:



When connecting a DVD player:

- ⏻/⏻ : Turns on and off the power.
- ▶ : Starts playback.
- ▶▶ :
 - Fast-forward the track when pressed and held.
 - Skip to the beginning of the next tracks when pressed briefly.
- ◀◀ :
 - Reverses the track when pressed and held.
 - Go back to the beginning of the current track when pressed briefly.
 - Go back to the beginning of the previous tracks when pressed consecutively.
- : Stops playback.

Note:

When you press the above buttons, the display shows “DVD” and its operation mode (such as ▶, ■).

When connecting a VCR:

- ⏻/⏻ : Turns on and off the power.
- ▶ : Starts playback.
- ▶▶ : Fast-winds a tape when pressed and held.
- ◀◀ : Rewinds a tape when pressed and held.
- : Stops playback.

Note:

When you press the above buttons, the display shows “VCR” and its operation mode (such as ▶, ■).

3 Adjust the volume.

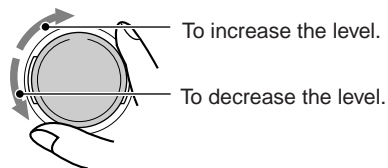

4 Adjust the sound you want. (See page 27.)

CD CHANGER OPERATIONS

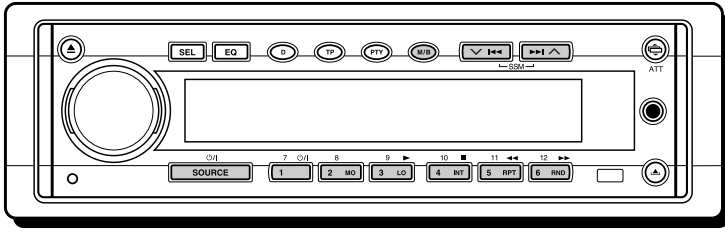
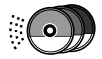

We recommend that you use one of the CH-X series with your unit.

If you have another CD automatic changer, consult your JVC IN-CAR ENTERTAINMENT dealer for connections.

- For example, if your CD automatic changer is one of the KD-MK series, you need a cord (KS-U15K) for connecting it to this unit.

Before operating your CD automatic changer:

- Refer also to the Instructions supplied with your CD changer.
- If no discs are in the magazine of the CD changer or the discs are inserted upside down, "NO DISC" will appear on the display. If this happens, remove the magazine and set the discs correctly.
- If "RESET 1" – "RESET 8" appears on the display, something is wrong with the connection between this unit and the CD changer. If this happens, check the connection and make sure the cords are connected firmly. Then, press the reset button of the CD changer.

Playing CDs

Select the CD automatic changer (CD CHANGER).

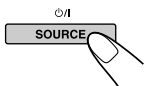

When you select a source, the power automatically comes on.

Each time you press the button, the source changes as described on page 7.

Disc number

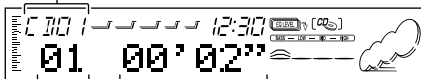

Track number

Elapsed playing time

To fast-forward or reverse the track

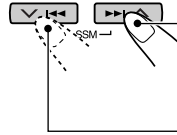

Press and hold **▶▶▶**, while playing a disc, to fast-forward the track.

Press and hold **◀◀◀**, while playing a disc, to reverse the track.

To go to the next track or the previous tracks

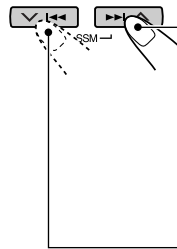

Press **▶▶▶** **▲** briefly, while playing a disc, to go ahead to the beginning of the next track. Each time you press the button consecutively, the beginning of the next track is located and played back.

Press **◀◀◀** **▼** briefly, while playing a disc, to go back to the beginning of the current track. Each time you press the button consecutively, the beginning of the previous tracks is located and played back.



To go to a particular disc directly

Press the number button corresponding to the disc number to start its playback (while the CD changer is playing).



- To select a disc number from 1 – 6: Press 1 (7) – 6 (12) briefly.
- To select a disc number from 7 – 12: Press and hold 1 (7) – 6 (12) for more than 1 second.

Disc number

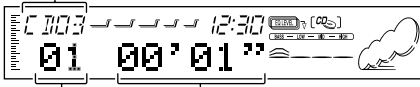

Track number Elapsed playing time

Ex.: When disc number 3 is selected

To play back tracks repeatedly (Repeat Play)

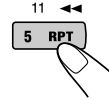
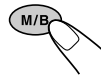

- 1 Press M/B (mode/band) while playing a disc. This unit enters the functions mode.
- 2 Press RPT (repeat) while still in the functions mode, so that the RPT indicator lights up on the display. Then, each time you press RPT, the repeat play mode changes as follows:



Mode	RPT Indicator	Plays repeatedly
RPT1	Lights	The current track (or specified track).
RPT2	Flashes	All tracks of the current disc (or specified disc).

Selecting CD playback modes

To play back tracks at random (Random Play)

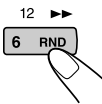
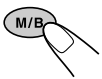

- 1 Press M/B (mode/band) while playing a disc. This unit enters the functions mode.
- 2 Press RND (random) while still in the functions mode, so that the RND indicator lights up on the display. Then, each time you press RND, the random play mode changes as follows:



Mode	RND Indicator	Plays at random
RND1	Lights	All tracks of the current disc, then the tracks of the next disc and so on.
RND2	Flashes	All tracks of all discs inserted in the magazine.

To play back only intros (Intro scan)

You can play back the first 15 seconds of each track sequentially.

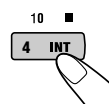

- 1 Press M/B (mode/band) while playing a disc. This unit enters the functions mode.
- 2 Press INT (intro scan) while still in the functions mode, so that "INT" appears on the display. Then, each time you press INT, the intro scan mode changes as follows:



Mode	Indicator	Plays the beginnings (15 seconds)
INT1	Track number flashes	Of all tracks on all inserted discs.
INT2	Disc number flashes	Of the first track on each inserted disc.

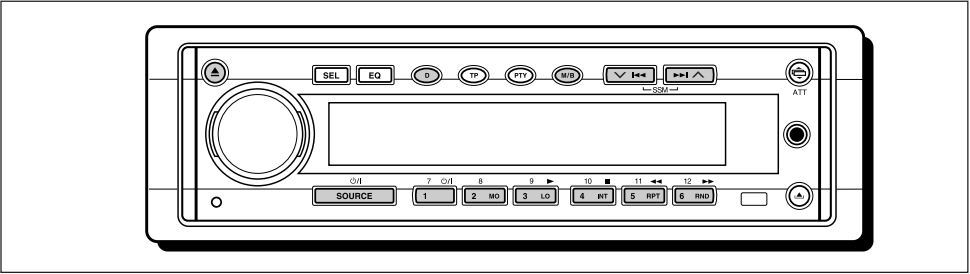

We recommend that you use DAB (Digital Audio Broadcasting) tuner KT-DB1500 with your unit. If you have another DAB tuner, consult your JVC IN-CAR ENTERTAINMENT dealer.

- Refer also to the Instructions supplied with your DAB tuner.

What is DAB system?

DAB is one of the digital radio broadcasting systems available today. It can deliver CD quality sound without any annoying interference and signal distortion.

Furthermore, it can carry text, pictures and data.

In contrast to FM broadcast, where each programme is transmitted on its own frequency, DAB combines several programmes (called “services”) to form one “ensemble.”

With the DAB tuner connected with this unit, you can enjoy these DAB services.

Tuning into an ensemble and one of the services

A typical ensemble has 6 or more programmes (services) broadcast at the same time. After tuning into an ensemble, you can select a service you want to listen to.

1 Select the DAB tuner.

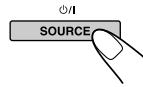

When you select a source, the power automatically comes on. Each time you press the button, the source changes as described on page 7.

2 Select the DAB band (DAB1, DAB2, or DAB3).

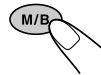

Each time you press and hold the button for more than 1 second, the DAB band changes as follows:

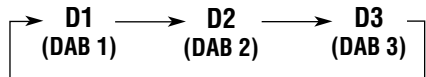

Note:

This receiver has three DAB bands (DAB 1, DAB 2, DAB 3). You can use any of them to tune into an ensemble.

3 Start searching an ensemble.

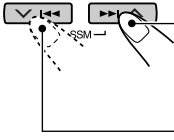

Press ►► ▲ to search ensembles of higher frequencies.

Press ▼ I◄◄ to search ensembles of lower frequencies.

When an ensemble is received, searching stops.

To stop searching before an ensemble is received, press the same button you have pressed for searching.

4 Select a service you want to listen to.



1 Press M/B (mode/band).

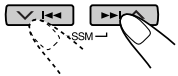

2 Press ►►► ▲ or ▼ I◄◄ to select a service you want.

To change the display information while tuning into an ensemble

Normally service name is shown on the display. If you want to change the display information, press D (display).

Each time you press the button, the following information appears on the display for a while.

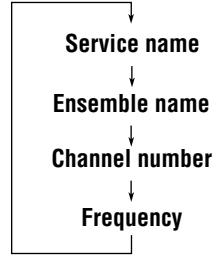

To tune into a particular ensemble without searching:

- 1 Press SOURCE to select DAB tuner as the source.
- 2 Press and hold M/B (mode/band) for more than 1 second repeatedly to select the DAB band (DAB 1, DAB 2 or DAB 3).
- 3 Press and hold ►►► ▲ or ▼ I◄◄ for more than 1 second. "MANUAL" flashed on the display.
- 4 Press ►►► ▲ or ▼ I◄◄ repeatedly until the ensemble you want is reached.
 - If you hold down the button, the ensembles keep changing until you release the button.

Storing DAB services in memory

You can preset up to 6 DAB services in each DAB band (DAB1, DAB2 and DAB3) manually.

1 Select the DAB tuner.

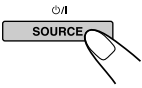

When you select a source, the power automatically comes on. Each time you press the button, the source changes as described on page 7.

2 Select the DAB band (DAB 1, DAB 2 or DAB 3) you want.



Each time you press and hold the button for more than 1 second, the DAB band changes as follows:

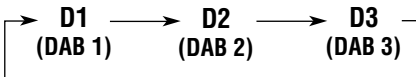

3 Tune into an ensemble you want.

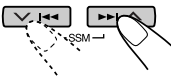

4 Select a service of the ensemble you want.



1 Press M/B (mode/band).

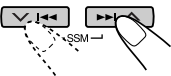
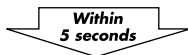

2 Press and hold or to select a service you want.

5 Press and hold the number button (in this example, 1) you want to store the selected service into for more than 2 seconds.

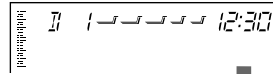

"P 1" flashes for a while.

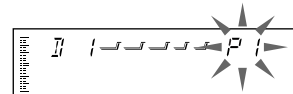

6 Repeat the above procedure to store other DAB services into other preset numbers.

Notes:

- A previously preset DAB service is erased when a new DAB service is stored in the same preset number.
- Preset DAB services are erased when the power supply to the memory circuit is interrupted (for example, during battery replacement). If this occurs, preset the DAB services again.

Tuning into a preset DAB service

You can easily tune into a preset DAB service. Remember that you must store services first. If you have not stored them yet, see page 43.

1 Select the DAB tuner.

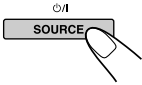

When you select a source, the power automatically comes on. Each time you press the button, the source changes as described on page 7.

2 Select the DAB band (DAB1, DAB2 or DAB3) you want.

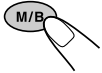

Each time you press and hold the button for more than 1 second, the DAB band changes as follows:



3 Select the number (1 – 6) for the preset DAB service you want.

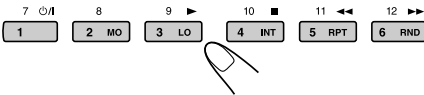

What you can do more with DAB

Tracing the same program automatically (Alternative Reception)

You can keep listening to the same program.

- **While receiving a DAB service:**
When driving in an area where a service cannot be received, this unit automatically tunes in another ensemble or FM RDS station, broadcasting the same program.
- **While receiving an FM RDS station:**
When driving in an area where a DAB service is broadcasting the same program as the FM RDS station is broadcasting, this unit automatically tunes into the DAB service.

Note:

When reception switches between DAB and FM, the listening volume level may increase or decrease inconveniently. This change in the volume level results from unequal audio injection levels at broadcaster site, but not from the malfunction of this unit.

To use Alternative Reception

When shipped from the factory, Alternative Reception is activated.

- See also “Changing the general settings (PSM)” on page 30.

1 Press and hold SEL (select) for more than 2 seconds so that one of the PSM items appears on the display.

2 Press **▶▶|** **▲** or **▼** **|◀◀** to select “DAB AF” (alternative frequency).

3 Turn the control dial to select the desired mode.

- **AF ON:** Traces the program among DAB services and FM RDS stations — Alternative Reception. The AF indicator lights up on the display (see page 11).
- **AF OFF:** Deactivates Alternative Reception.

Note:

When Alternative Reception (for DAB services) is activated, Network-Tracking Reception (for RDS stations: see page 11) is also activated automatically. On the other hand, Network-Tracking Reception cannot be deactivated without deactivating Alternative Reception.

4 Press SEL (select) to finish the setting.



Sound modes (preset value settings)

The list below shows the preset value settings for each sound mode. Even after you have changed their settings, you can reset to the factory settings by reassigning the preset values below. (See page 29 for reassignment procedures.)

Indication	Preset equalizing values							
	FREQ.	WIDTH	LOW LEVEL	FREQ.	WIDTH	MID LEVEL	FREQ.	HIGH LEVEL
FLAT	50 Hz	1	00	700 Hz	1	00	8 kHz	00
Hard Rock	80 Hz	2	+03	700 Hz	1	00	8 kHz	+02
R & B	80 Hz	3	+03	2 kHz	2	+01	12 kHz	+03
POP	120 Hz	1	+02	2 kHz	2	+01	12 kHz	+02
JAZZ	80 Hz	1	+03	1 kHz	1	+01	8 kHz	+03
DanceMusic	50 Hz	2	+04	700 Hz	1	-02	8 kHz	+01
Country	50 Hz	4	+02	700 Hz	1	00	12 kHz	+02
Reggae	80 Hz	1	+03	2 kHz	2	+02	12 kHz	+02
Classic	120 Hz	1	+03	1 kHz	1	00	8 kHz	+02
User 1	50 Hz	1	00	700 Hz	1	00	8 kHz	00
User 2	50 Hz	1	00	700 Hz	1	00	8 kHz	00
User 3	50 Hz	1	00	700 Hz	1	00	8 kHz	00

Available characters

- You can use the following characters to assign names to CDs, and external components. (See page 34.)
- You can display the information (album title, performer name, song title, etc.) as ID3v1 tags when you playback an MP3 file with this unit. (See pages 20 and 47.)

Capital letters

A	B	C	D	E
F	G	H	I	J
K	L	M	N	O
P	Q	R	S	T
U	V	W	X	Y
Z	space			

Small letters

a	b	c	d	e
f	g	h	i	j
k	l	m	n	o
p	q	r	s	t
u	v	w	x	y
z	space			



Numbers and symbols

0	1	2	3	4
5	6	7	8	9
!	"	#	\$	%
&	'	()	*
+	,	-	.	/
:	;	<	=	>
?	@	_	`	space



TROUBLESHOOTING

What appears to be trouble is not always serious. Check the following points before calling a service center.

	Symptoms	Causes	Remedies
General Playback	• Disc cannot be played back.	Disc is inserted upside down. ("DISC ERR" appears on the display.)	Insert the disc correctly.
	• Sound is sometimes interrupted.	You are driving on rough roads.	Stop playback while driving on rough roads.
		Disc is scratched.	Change the disc.
		Connections are incorrect.	Check the cords and connections.
	• Sound cannot be heard from the speakers.	The volume level is set to the minimum level.	Adjust it to the optimum level.
		Connections are incorrect.	Check the cords and connections.
	• "DISC ERR" appears on the display.	Contents on the disc are not compatible with the unit.	Change the disc.
• "NO DISC" or "EJECT ERR" appears on the display and disc cannot be ejected. • No message appears on the display but disc cannot be ejected.	The unit may function incorrectly.	While pressing  , press and hold  for more than 2 seconds. (Be careful not to drop the disc when ejecting.)	
• This unit or CD changer does not work at all.	The built-in microcomputer may function incorrectly due to noise, etc.	Press the reset button on the control panel. (See page 2.)	
FM/AM	• SSM (Strong-station Sequential Memory) automatic preset does not work.	Signals are too weak.	Store stations manually.
	• Static noise while listening to the radio.	The antenna is not connected firmly.	Connect the antenna firmly.
CD Changer	• "NO DISC" appears on the display.	No disc is in the magazine.	Insert a disc.
	• "RESET 8" appears on the display.	This unit is not connected to a CD changer correctly.	Connect this unit and the CD changer correctly and press the reset button of the CD changer.
	• "RESET 1" – "RESET 7" appears on the display.	_____	Press the reset button of the CD changer.



Symptoms	Causes	Remedies
<ul style="list-style-type: none"> • Disc cannot be played back. 	No MP3 files are recorded on the disc.	Change the disc.
	MP3 files do not have the extension code—mp3 in their file names.	Add the extension code—mp3 to their file names.
	MP3 files are not recorded in the format compliant with ISO 9660 Level 1 or 2.	Change the disc. (Record MP3 files using a compliant application.)
<ul style="list-style-type: none"> • Noise is generated. 	The file played back is not an MP3 file (although it has the extension code—mp3).	Skip to another file or change the disc. (Do not add the extension code—mp3 to non-MP3 files.)
<ul style="list-style-type: none"> • A longer readout time is required (“FILE CHECK” keeps flashing on the display). 	Readout time varies due to the complexity of the directory/file configuration.	Do not use too many hierarchies and directories. Also, do not record any other types of audio tracks together with MP3 files.
<ul style="list-style-type: none"> • Files cannot be played back as you have intended them to play. 	Playback order is determined when the files are recorded.	_____
<ul style="list-style-type: none"> • Elapsed playing time is not correct. 	This sometimes occurs during play. This is caused by how the files are recorded on the disc.	_____
<ul style="list-style-type: none"> • “MP3” flashes on the display. 	The current directory does not contain any MP3 files.	Select another directory.
<ul style="list-style-type: none"> • Correct characters are not displayed. (Tag Display, e.g. album name) 	This unit can display alphabets (capital: A–Z, small: a–z), numbers and symbols. (See page 45.)	_____

MP3 Playback



Handling discs

This unit has been designed to reproduce the discs bearing the following marks.



You can also play back your original CD-Rs (Recordable) and CD-RWs (Rewritable) either in audio CD format or in MP3 format.

How to handle discs

When removing a disc from its case, press down the center holder of the case and lift the disc out, holding it by the edges.

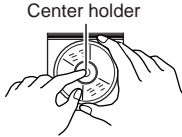

- Always hold the disc by the edges. Do not touch its recording surface.

When storing a disc into its case, gently insert the disc around the center holder (with the printed surface facing up).

- Make sure to store discs into the cases after use.

To keep discs clean

A dirty disc may not play correctly. If a disc does become dirty, wipe it with a soft cloth in a straight line from center to edge.



To play new discs

New discs may have some rough spots around the inner and outer edges. If such a disc is used, this unit may reject the disc.

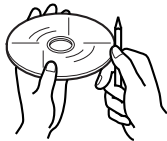

To remove these rough spots, rub the edges with a pencil or ball-point pen, etc.

Moisture condensation

Moisture may condense on the lens inside the unit in the following cases:

- After starting the heater in the car.
 - If it becomes very humid inside the car.
- Should this occur, the unit may malfunction. In this case, eject the disc and leave the unit turned on for a few hours until the moisture evaporates.

CAUTIONS:

- Do not insert 8 cm (3 3/16") discs (single CDs) into the loading slot. (Such discs cannot be ejected.)
- Do not insert any disc of unusual shape — like a heart or flower; otherwise, it will cause a malfunction.
- Do not expose discs to direct sunlight or any heat source or place them in a place subject to high temperature and humidity. Do not leave them in a car.
- Do not use any solvent (for example, conventional record cleaner, spray, thinner, benzine, etc.) to clean discs.

When playing a CD-R or CD-RW

You can play back your original CD-Rs or CD-RWs recorded in audio CD format or in MP3 format. (However, they may not be played back depending on their characteristics or recording conditions.)

- User-edited CD-Rs (Recordable) and CD-RWs (Rewritable), where audio CD tracks are recorded, can be played back only if they are already "finalized."
- Before playing back CD-Rs or CD-RWs, read their instructions or cautions carefully.
- Some CD-Rs or CD-RWs may not be played back on this unit because of their disc characteristics, damage or stain on them, or if the player's lens is dirty.
- CD-Rs or CD-RWs are susceptible to high temperatures or high humidity; so do not leave them inside your car.
- CD-RWs may require a longer readout time. (This is caused by the fact that the reflectance of CD-RWs is lower than for regular CDs.)

About mistracking:

Mistracking may result from driving on extremely rough roads. This does not damage the unit and the disc, but will be annoying. We recommend that you stop disc playback while driving on such rough roads.

AUDIO AMPLIFIER SECTION

Maximum Power Output:

Front: 50 W per channel

Rear: 50 W per channel

Continuous Power Output (RMS):

Front: 19 W per channel into 4 Ω , 40 Hz to 20 000 Hz at no more than 0.8 % total harmonic distortion.

Rear: 19 W per channel into 4 Ω , 40 Hz to 20 000 Hz at no more than 0.8 % total harmonic distortion.

Load Impedance: 4 Ω (4 Ω to 8 Ω allowance)

Equalizer Control Range:

LOW: ± 12 dB (50 Hz, 80 Hz, 120 Hz)

MID: ± 12 dB (700 Hz, 1 kHz, 2 kHz)

HIGH: ± 12 dB (8 kHz, 12 kHz)

Frequency Response: 40 Hz to 20 000 Hz

Signal-to-Noise Ratio: 70 dB

Line-In Level/Impedance: 1.5 V/20 k Ω load

Auxiliary Input jack: (3.5 mm dia. stereo mini jack)
(analog)

Line-Out Level/Impedance:

4.0 V/20 k Ω load (full scale)

Output Impedance: 1 k Ω

TUNER SECTION

Frequency Range:

FM: 87.5 MHz to 108.0 MHz

AM: (MW) 522 kHz to 1 620 kHz

(LW) 144 kHz to 279 kHz

[FM Tuner]

Usable Sensitivity: 11.3 dBf (1.0 μ V/75 Ω)

50 dB Quieting Sensitivity:

16.3 dBf (1.8 μ V/75 Ω)

Alternate Channel Selectivity (400 kHz):

65 dB

Frequency Response: 40 Hz to 15 000 Hz

Stereo Separation: 30 dB

Capture Ratio: 1.5 dB

[MW Tuner]

Sensitivity: 20 μ V

Selectivity: 35 dB

[LW Tuner]

Sensitivity: 50 μ V

CD PLAYER SECTION

Type: Compact disc player

Signal Detection System: Non-contact optical pickup (semiconductor laser)

Number of channels: 2 channels (stereo)

Frequency Response: 5 Hz to 20 000 Hz

Dynamic Range: 98 dB

Signal-to-Noise Ratio: 102 dB

Wow and Flutter: Less than measurable limit

MP3 decoding format: MPEG1/2 Audio Layer 3

Max. Bit Rate: 320 Kbps

GENERAL

Power Requirement:

Operating Voltage: DC 14.4 V

(11 V to 16 V allowance)

Grounding System: Negative ground

Allowable Operating Temperature: 0°C to +40°C

Dimensions (W x H x D):

Installation Size: 182 mm x 52 mm x 161 mm

Panel Size: 188 mm x 58 mm x 17 mm

Mass: 1.8 kg (excluding accessories)

Design and specifications subject to change without notice.



Having TROUBLE with operation?

Please reset your unit

Refer to page of How to reset your unit

Haben Sie PROBLEME mit dem Betrieb?

Bitte setzen Sie Ihr Gerät zurück

Siehe Seite Zurücksetzen des Geräts

Vous avez des PROBLÈMES de fonctionnement?

Réinitialisez votre appareil

Référez-vous à la page intitulée Comment réinitialiser votre appareil

Hebt u PROBLEMEN met de bediening?

Stel het apparaat terug

Zie de pagina met de paragraaf Het apparaat terugstellen

JVC

VICTOR COMPANY OF JAPAN, LIMITED



EN, GE, FR, NL



0401MNMDWJES

**A If your car is equipped with the ISO connector
Wenn Ihr Auto mit ISO-Steckern ausgestattet ist
Si votre voiture est équipée d'un connecteur ISO
Indien uw auto is uitgerust met de ISO-connector**

- Connect the ISO connectors as illustrated.
- Die ISO-Stecker wie abgebildet anschließen.
- Connectez les connecteurs ISO comme montré sur l'illustration.
- Sluit de ISO-connectoren aan zoals op het voorbeeld is aangegeven.

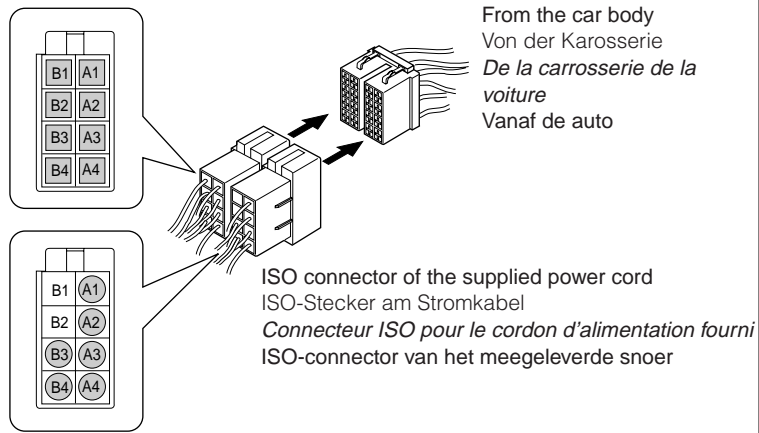

View from the lead side
Ansicht von der Leitungsseite
Vue à partir du côté des fils
Aanzicht vanaf het snoer

From the car body
Von der Karosserie
De la carrosserie de la voiture
Vanaf de auto

ISO connector of the supplied power cord
ISO-Stecker am Stromkabel
Connecteur ISO pour le cordon d'alimentation fourni
ISO-connector van het meegeleverde snoer

**For some VW/Audi or Opel (Vauxhall) automobile
Für manche VW/Audi oder Opel (Vauxhall) Fahrzeuge
Pour certaine voiture VW/Audi ou Opel (Vauxhall)
Voor bepaalde modellen VW/Audi of Opel (Vauxhall) geldt**

You may need to modify the wiring of the supplied power cord as illustrated.

- Contact your authorized car dealer before installing this unit.
- Sie müssen evtl. die Verdrahtung des mitgelieferten Stromkabels wie abgebildet ändern.
- Wenden Sie sich an Ihre Vertragswerkstatt, bevor Sie das Gerät einbauen.
- Vous aurez peut-être besoin de modifier le câblage du cordon d'alimentation fourni comme montré sur l'illustration.
- Contactez votre revendeur automobile autorisé avant d'installer l'appareil.
- Wellicht moet u de bedrading van het meegeleverde snoer als in het voorbeeld aanpassen.
- Neem contact op met uw officiële autodealer alvorens dit apparaat te installeren.

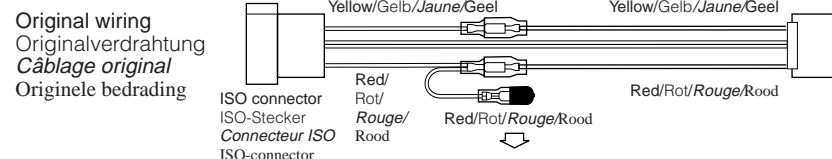

Original wiring
Originalverdrahtung
Câblage original
Originele bedrading

Modified wiring [1]
Geänderte Verdrahtung [1]
Câblage modifié [1]
Aangepaste bedrading [1]

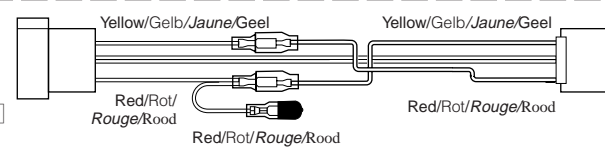

Use modified wiring [2] if the unit does not turn on.
Geänderte Verdrahtung [2] verwenden, wenn das Gerät so nicht an geht.
Utilisez le câblage modifié [2] si l'appareil ne se met pas sous tension.
Pas de bedrading [2] aan indien het apparaat niet reageert bij inschakelen.

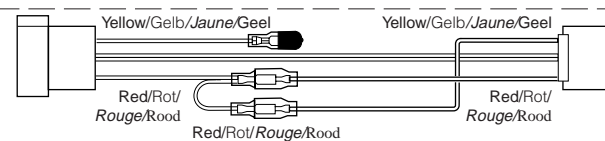

**B Connections without using the ISO connectors / Anschlüsse ohne ISO-Stecker / Connexions sans l'utilisation des connecteurs ISO /
Verbindingen zonder ISO-connectoren**

Before connecting: Check the wiring in the vehicle carefully. Incorrect connection may cause serious damage to this unit.

Vor dem Anschließen: Die Verdrahtung im Fahrzeug sorgfältig überprüfen. Falsche Anschlüsse können ernsthafte Schäden am Gerät hervorrufen.

Avant de commencer la connexion: Vérifiez attentivement le câblage du véhicule. Une connexion incorrecte peut endommager sérieusement l'appareil.

Alvorens de verbindingen tot stand te brengen: Moet u de bedrading in de auto zorgvuldig. Het apparaat kan door verkeerde verbindingen ernstige schade oplopen.

- 1 Cut the ISO connector.
- 2 Connect the colored leads of the power cord to the car battery, speakers and power aerial (if any) in the following sequence.
 - 1 Black: ground
 - 2 Yellow: to car battery (constant 12 V)
 - 3 Red: to an accessory terminal
 - 4 Blue with white stripe: to power aerial (200 mA max.)
 - 5 Orange with white stripe: to car light control switch
 - 6 Brown: to cellular phone system (For details, refer to the instructions of the cellular phone.)
 - 7 Others: to speakers
- 3 Connect the aerial cord.
- 4 Finally connect the wiring harness to the unit.

- 1 Den ISO-Stecker afsnijden.
- 2 Die farbigen Leitungen des Spannungsversorgungskabels an der Autobatterie, den Lautsprechern und dem Motorantenne (sofern vorhanden) in folgender Reihenfolge anschließen.
 - 1 Schwarz: Erdung
 - 2 Gelb: an Autobatterie (konstant 12 V)
 - 3 Rot: zur einer Zubehöransteckleuchte
 - 4 Blau mit weißem Streifen: zur Motorantenne (max. 200 mA)
 - 5 Orange mit weißem Streifen: zur Autolichtschalter
 - 6 Braun: zur Mobiltelefon (Weitere Informationen entnehmen Sie bitte der Bedienungsanleitung des Mobiltelefons.)
 - 7 Andere: zur Lautsprecher
- 3 Das Antennenkabel anschließen.
- 4 Die Kabelbäume am Gerät anschließen.

- 1 Coupez le connecteur ISO.
- 2 Connectez les fils de couleur du cordon d'alimentation à la batterie de la voiture, aux enceintes et à l'antenne automatique (s'il y en a une) dans l'ordre suivant.
 - 1 Noir: à la masse
 - 2 Jaune: à la batterie de la voiture (12 V constant)
 - 3 Rouge: à une borne accessoire
 - 4 Bleu avec bande blanche: à l'antenne automatique (200 mA max.)
 - 5 Orange avec bande blanche: à l'interrupteur d'éclairage de la voiture
 - 6 Marron: à un système de téléphone cellulaire (Pour les détails, se référer aux instructions du téléphone cellulaire.)
 - 7 Autres: aux enceintes
- 3 Connectez le cordon d'antenne.
- 4 Finalement, connectez le faisceau de fils à l'appareil.

- 1 Knip de ISO-connector los.
- 2 Sluit de gekleurde snoerdraden van de stroomkabel in de hierna genoemde volgorde aan op de accu van de auto, de luidsprekers en de antenne (indien aanwezig).
 - 1 Zwart: aarde
 - 2 Geel: naar de accu van de auto (constant 12 V)
 - 3 Rood: naar de aansluitklem van de accessoire
 - 4 Blauw met witte streep: naar de antenne (Max. 200 mA)
 - 5 Oranje met witte streep: naar de schakelaar voor de autoverlichting
 - 6 Bruin: naar het mobiele-telefoonsysteem (Lees voor meer informatie de instructies die bij de mobiele telefoon worden geleverd.)
 - 7 Andere: naar de speakers
- 3 Sluit de antenne aan.
- 4 Verbind de draadbundel daarna met het apparaat.

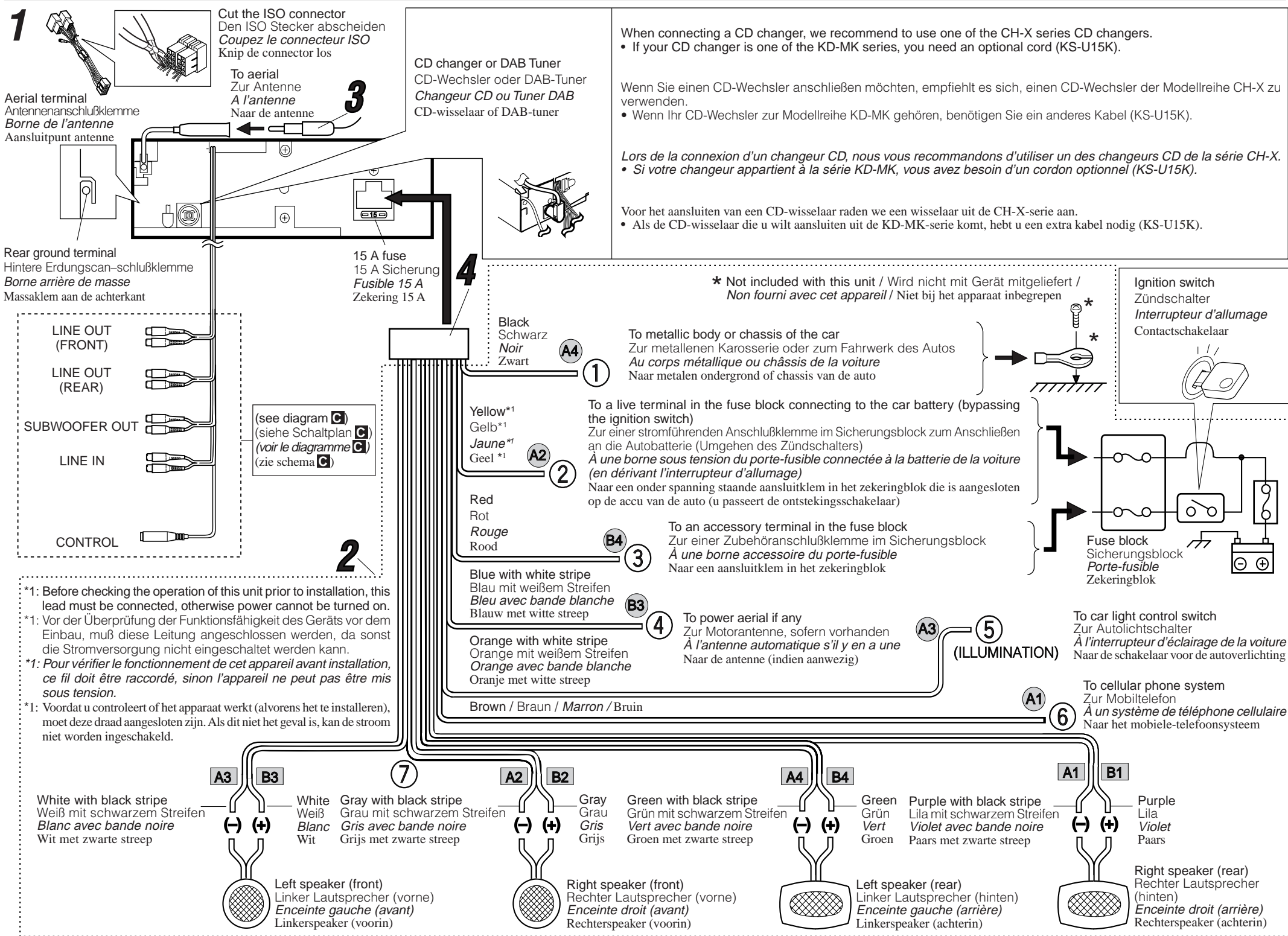

*1: Before checking the operation of this unit prior to installation, this lead must be connected, otherwise power cannot be turned on.
*1: Vor der Überprüfung der Funktionsfähigkeit des Geräts vor dem Einbau, muß diese Leitung angeschlossen werden, da sonst die Stromversorgung nicht eingeschaltet werden kann.
*1: Pour vérifier le fonctionnement de cet appareil avant installation, ce fil doit être raccordé, sinon l'appareil ne peut pas être mis sous tension.
*1: Voordat u controleert of het apparaat werkt (alvorens het te installeren), moet deze draad aangesloten zijn. Als dit niet het geval is, kan de stroom niet worden ingeschakeld.

When connecting a CD changer, we recommend to use one of the CH-X series CD changers.
• If your CD changer is one of the KD-MK series, you need an optional cord (KS-U15K).
Wenn Sie einen CD-Wechsler anschließen möchten, empfiehlt es sich, einen CD-Wechsler der Modellreihe CH-X zu verwenden.
• Wenn Ihr CD-Wechsler zur Modellreihe KD-MK gehören, benötigen Sie ein anderes Kabel (KS-U15K).
Lors de la connexion d'un changeur CD, nous vous recommandons d'utiliser un des changeurs CD de la série CH-X.
• Si votre changeur appartient à la série KD-MK, vous avez besoin d'un cordon optionnel (KS-U15K).
Voor het aansluiten van een CD-wisselaar raden we een wisselaar uit de CH-X-serie aan.
• Als de CD-wisselaar die u wilt aansluiten uit de KD-MK-serie komt, hebt u een extra kabel nodig (KS-U15K).

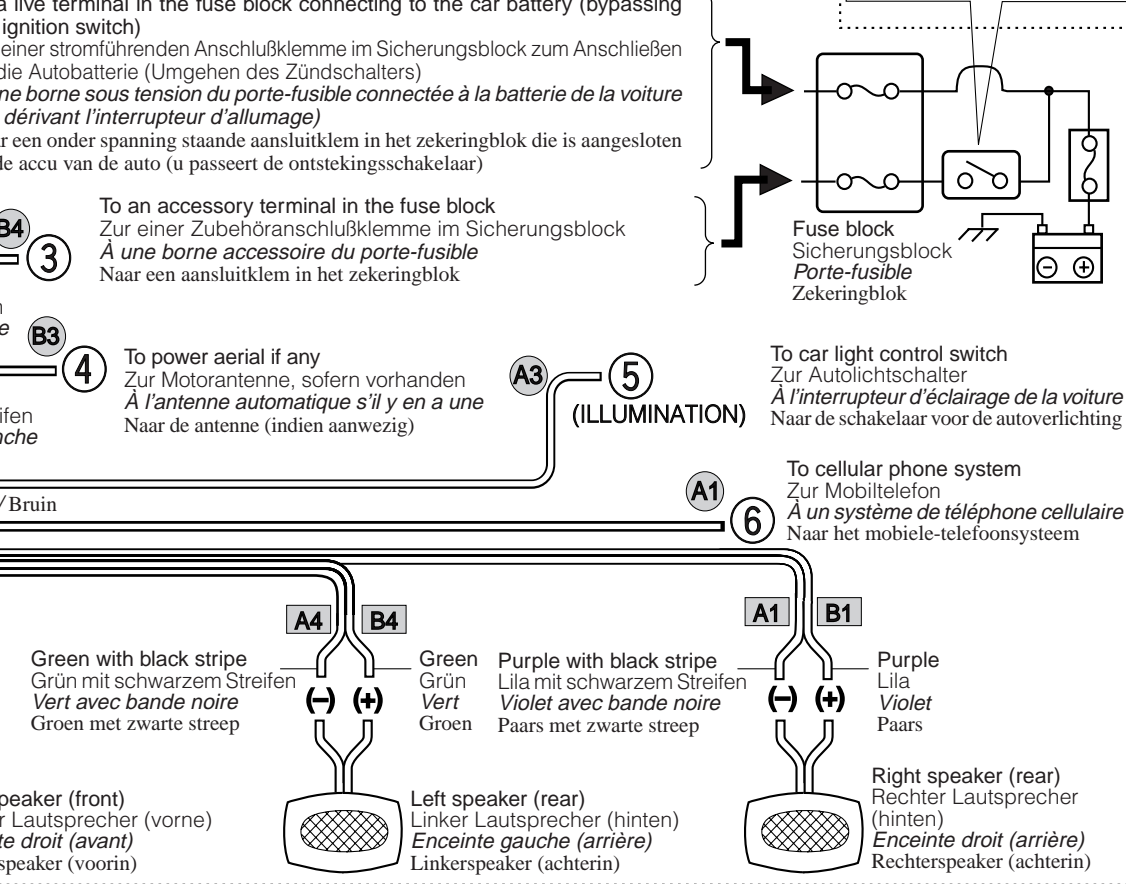
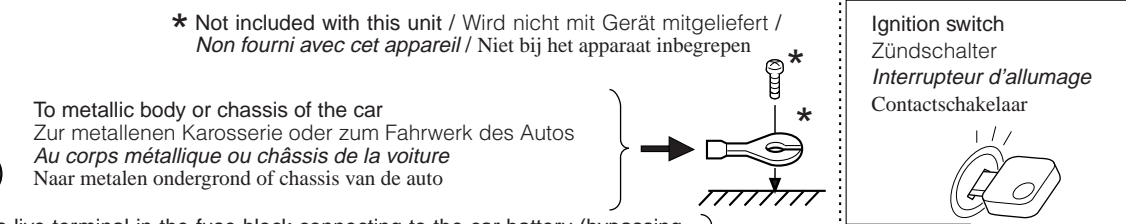

PRECAUTIONS on power supply and speaker connections:

- DO NOT connect the speaker leads of the power cord to the car battery; otherwise, the unit will be seriously damaged.
- Connect the black lead (ground), yellow lead (to car battery, constant 12 V), and red lead (to an accessory terminal) correctly.
- BEFORE connecting the speaker leads of the power cord to the speakers, check the speaker wiring in your car.
 - If the speaker wiring in your car is as illustrated in Fig. 1 and Fig. 2 below, DO NOT connect the unit using that original speaker wiring. If you do, the unit will be seriously damaged.
 - Redo the speaker wiring so that you can connect the unit to the speakers as illustrated in Fig. 3.
 - If the speaker wiring in your car is as illustrated in Fig. 3, you can connect the unit using the original speaker wiring in your car.
 - If you are not sure of the speaker wiring of your car, consult your JVC IN-CAR ENTERTAINMENT dealer.

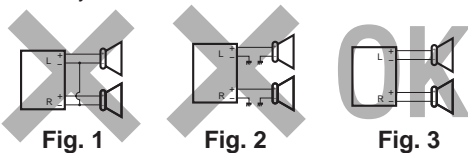

VORSICHTSMASSEGEN beim Anschließen der Stromversorgung und Lautsprecher:

- Die Lautsprecherleitungen des Netzkabels NICHT an der Autobatterie anschließen, da sonst das Gerät schwer beschädigt wird.
- Die schwarze Leitung (Erdung), die gelbe Leitung (zur Autobatterie, konstant 12 V) und die rote Leitung (zur Zubehöransteckleuchte) richtig anschließen.
- VOR dem Anschließen der Lautsprecherleitungen des Spannungsvorsorgungskabels an die Lautsprecher, die Lautsprecherverdrahtung in Ihrem Auto überprüfen.
 - Ist die Lautsprecherverdrahtung wie unten in "Fig. 1" und "Fig. 2" abgebildet, das Gerät NICHT mit der Originalverdrahtung der Lautsprecher anschließen, da sonst das Gerät schwer beschädigt wird.
 - Die Lautsprecherverdrahtung erneuern, so daß Sie das Gerät an den Lautsprechern wie in "Fig. 3" abgebildet anschließen können.
 - Ist die Lautsprecherverdrahtung in Ihrem Auto wie in "Fig. 3" abgebildet, können Sie das Gerät mit der Originalverdrahtung der Lautsprecher in Ihrem Auto anschließen.
 - Sind Sie sich über die Lautsprecherverdrahtung in Ihrem Auto nicht sicher, wenden Sie sich an Ihren Autohändler.

PRECAUTIONS sur l'alimentation et la connexion des enceintes:

- NE CONNECTEZ PAS les fils d'enceintes du cordon d'alimentation à la batterie; sinon, l'appareil serait sérieusement endommagé.
- Connectez correctement le fil noir (à la masse), le fil jaune (à la batterie de la voiture, 12 V constant) et le fil rouge (à la prise accessoire).
- AVANT de connecter les fils d'enceintes du cordon d'alimentation aux enceintes, vérifiez le câblage des enceintes de votre voiture.
 - Si le câblage des enceintes de votre voiture est comme montré sur la Fig. 1 ou Fig. 2 ci-dessous, NE CONNECTEZ PAS l'appareil en utilisant ce câblage original des enceintes. Si vous le faites, l'appareil sera sérieusement endommagé. Recommencez le câblage des enceintes de façon que vous puissiez connecter l'appareil aux enceintes comme montré sur la Fig. 3.
 - Si le câblage des enceintes de votre voiture est comme montré sur la Fig. 3, vous pouvez connecter l'appareil en utilisant ce câblage original d'enceintes pour votre voiture.
 - Si vous n'êtes pas sûrs du câblage d'enceintes de votre voiture, consultez le concessionnaire de votre voiture.

VOORZORGSMAATREGELEN bij het verbinden van de stroomkabel met de speakers:

- Verbind de speakerdraden van de stroomkabel NIET met de accu van de auto; als u dit wel doet, zal het apparaat ernstige schade oplopen.
- Sluit de zwarte draad (aarde), de gele draad (naar de accu van de auto, constant 12 V) en de rode draad (naar de aansluitklem van de accessoire) op de juiste wijze aan.
- VOORDAT u de speakerdraden van de stroomkabel met de speakers verbindt, moet u de bedrading van de speakers in uw auto controleren.
 - Als de bedrading van de speakers eruit ziet zoals hieronder staat afgebeeld in Fig. 1 en Fig. 2, mag het apparaat NIET worden aangesloten met behulp van deze oorspronkelijke speakerbedrading. Als u dat wel doet, zal het apparaat ernstige schade oplopen.
 - Pas de bedrading van de speakers aan, zodat u het apparaat met de speakers kunt verbinden, zoals staat afgebeeld in Fig. 3.
 - Als de bedrading van de speakers eruit ziet zoals staat afgebeeld in Fig. 3, kunt u het apparaat aansluiten met behulp van de oorspronkelijke speakerbedrading in uw auto.
 - Als u twijfels hebt over de speakerbedrading in uw auto, moet u contact opnemen met uw autodealer.

C Connections Adding Other Equipment / Anschlüsse zum Hinzufügen von anderer Ausrüstung / Raccordement pour ajouter d'autres appareils / Aansluitingen voor het toevoegen van andere apparatuur

Amplifier / Verstärker / Amplificateur / Versterker

You can connect an amplifier and other equipment to upgrade your car stereo system.

- Connect the remote lead (blue with white stripe) to the remote lead of the other equipment so that it can be controlled through this unit.
- For amplifier only:
 - Connect this unit's line-out terminals to the amplifier's line-in terminals.
 - Disconnect the speakers from this unit, connect them to the amplifier. Leave the speaker leads of this unit unused.
 - To turn on/off the power amplifier switch, see page 32 (separate volume).
 - The line output level of this unit is kept high to maintain the hi-fi sounds reproduced from this unit.

When connecting an external amplifier to this unit, turn down the gain control on the external amplifier to obtain the best performance from this unit.

Sie können einen Verstärker oder ein anderes Gerät anschließen, um Ihre Autostereoanlage zu erweitern.

- Schließen Sie das Fernbedienungskabel (blau mit weißem Streifen) an das Fernbedienungskabel des anderen Geräts an, so daß es über dieses Gerät gesteuert werden kann.
- Nur für den Verstärker:
 - Die Anschlußklemmen am Ausgang dieses Gerät an den Anschlußklemmen des Eingangs des Verstärkers anschließen.
 - Die Lautsprecher von diesem Gerät abtrennen und am Verstärker anschließen. Die Lautsprecherleitungen dieses Geräts unbenutzt lassen.
 - So schaltet Sie die integrierte Endstufe aus/ein, siehe Seite 32 (separate Lautstärke).
 - Der Ausgangspegel dieses Geräts wird auf einem hohen Wert gehalten, um den HiFi-Klang zu unterstützen, den dieses Gerät reproduziert.

Wenn Sie einen externen Verstärker an dieses Gerät anschließen, stellen Sie den Verstärkungsregler des externen Verstärkers herunter, um die bestmögliche Leistung dieses Geräts zu erzielen.

Vous pouvez connecter un amplificateur ou autre appareil pour améliorer votre système autoradio.

- Connectez le fil de commande à distance (bleu avec bande blanche) au fil de commande à distance de l'autre appareil de façon qu'il puisse être commandé via cet appareil.
- Pour l'amplificateur seulement:
 - Raccorder les bornes de sortie ligne de cet appareil aux bornes d'entrée ligne de l'amplificateur.
 - Déconnectez les enceintes de cet appareil et connectez-les à l'amplificateur. Laissez les fils d'enceintes de cet appareil inutilisés.
 - Pour mettre en/hors service l'amplificateur de puissance, voir la page 32 (volume séparé).
 - Le niveau de sortie de ligne de cet appareil est maintenu à un niveau élevé pour maintenir une qualité Hi-Fi pour les sons reproduits par cet appareil.

Lors de la connexion d'un amplificateur extérieur à cet appareil, diminuez le réglage du gain sur l'amplificateur extérieur pour obtenir les meilleures performances de cet appareil.

Het is mogelijk om uw autostereosysteem uit te breiden met een versterker of andere apparatuur.

- Verbind de externe kabel (blauw met witte streep) met de externe kabel van het andere apparaat zodat deze op afstand vanaf deze apparaat kan worden bediend.
- Alleen voor een versterker:
 - Verbind de uitgang van het apparaat met de ingang van de versterker.
 - Koppel de speakers van dit apparaat los en verbind ze aan de versterker.
 - De stroomtoevoer voor de versterker in- of uitschakelen, zie bladzijde 32 (aparte uitgave).
 - Het uitgangsniveau van het geluid is hoog om het hifi-geluid van deze eenheid te behouden.

Wanneer u een extern apparaat op deze eenheid aansluit, moet u erop letten dat u de versterkingsfactor van de externe versterker laag houdt, zodat deze eenheid de beste prestaties levert.

Signal cord (not supplied with this unit)
Einzelleitung (nicht mit diesem Gerät mitgeliefert)
Cordon de signal (non fourni avec cet appareil)
Signaalkabel (wordt niet bij dit apparaat geleverd)

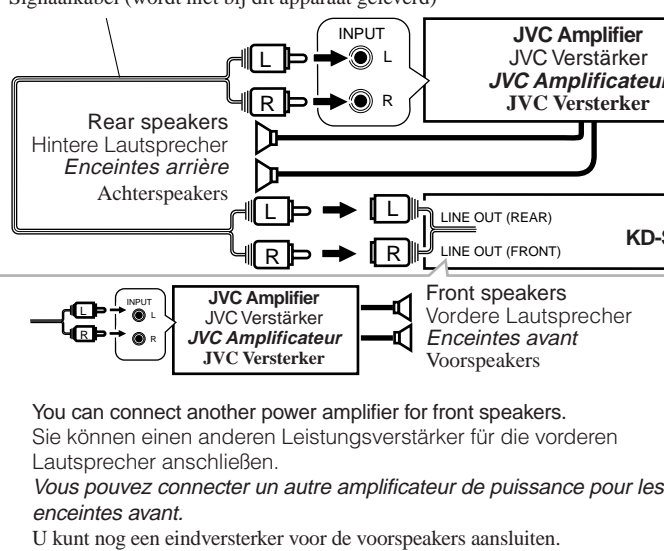

You can connect another power amplifier for front speakers. Sie können einen anderen Leistungsverstärker für die vorderen Lautsprecher anschließen. Vous pouvez connecter un autre amplificateur de puissance pour les enceintes avant. U kunt nog een eindversterker voor de voorspeakers aansluiten.

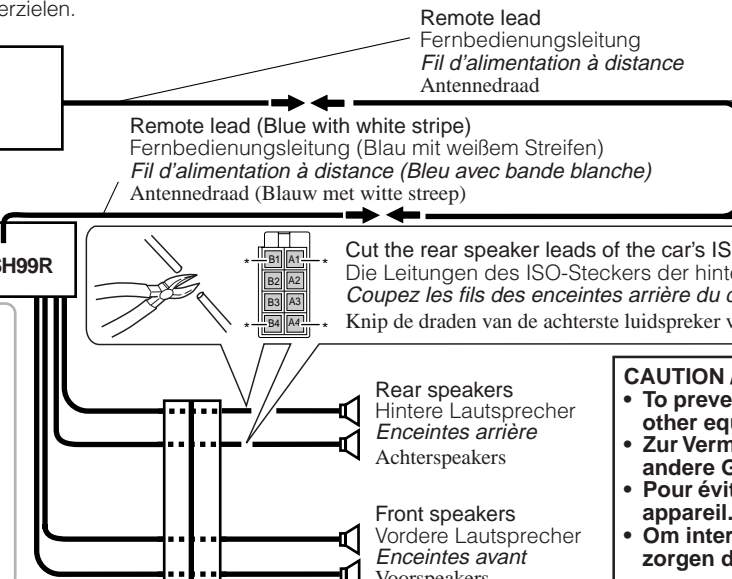

Remote lead
Fernbedienungsleitung
Fil d'alimentation à distance
Antennendraad

Y-connector (not supplied with this unit)
Y-Anschluß (nicht mitgeliefert)
Connecteur Y (non fourni avec cet appareil)
Y-connector (niet meegeleverd)

To power aerial if any
Zur Motorantenne, sofern vorhanden
À l'antenne automatique, s'il y en a une
Naar de antenne (indien aanwezig)

Cut the rear speaker leads of the car's ISO connector and connect them to the amplifier. Die Leitungen des ISO-Steckers der hinteren Lautsprecher durchtrennen und am Verstärker anschließen. Coupez les fils des enceintes arrière du connecteur ISO de la voiture et connectez-les à l'amplificateur. Knip de draden van de achterste luidspreker van de ISO-connector van de auto door en sluit deze draden aan op de versterker.

CAUTION / VORSICHT / PRECAUTION / LET OP:

- To prevent internal heat buildup inside this unit, place this unit UNDER the other equipment.
- Zur Vermeidung eines Hitzestaus in diesem Gerät, dieses Gerät UNTER die andere Geräteausrüstung stellen.
- Pour éviter un échauffement interne de cet appareil, placez-le SOUS l'autre appareil.
- Om interne verhitting van het apparaat te voorkomen, dient u ervoor te zorgen dat het apparaat ONDER de andere apparatuur wordt geplaatst.

CD changer and DAB tuner / CD-Wechsler und DAB-Tuner / Changeur CD et tuner DAB / CD-wisselaar en DAB-tuner

You can connect a JVC CD changer and/or a JVC DAB (Digital Audio Broadcasting) tuner.

- For their connections, refer to the instructions supplied with them.

Sie können einen CD-Wechsler und/oder einen DAB-Tuner (Tuner für digitalen Rundfunk) von JVC anschließen.

- Weitere Informationen über den Anschluß können Sie der Bedienungsanleitung entnehmen, die dem jeweiligen Gerät beiliegt.

Vous pouvez connecter un changeur CD JVC et/ou un tuner DAB (Digital Audio Broadcast) JVC.

- Pour leurs connexions, référez-vous aux modes d'emploi qui les accompagnent.

Het is mogelijk een JVC CD-wisselaar en/of JVC DAB-tuner (Digital Audio Broadcasting) aan te sluiten.

- Zie de instructies van deze apparaten voor meer informatie over het tot stand brengen van deze aansluiting.

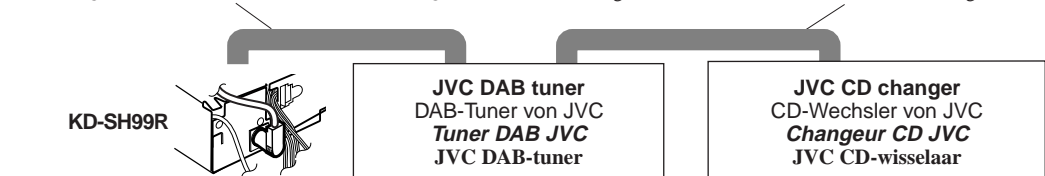

- You can connect both components in series as illustrated above.
- Es ist möglich, beide Komponenten in einer Serienschaltung entsprechend der obigen Darstellung anzuschließen.
- Vous pouvez connecter les deux appareils en série comme montré ci-dessus.
- Beide apparaten zijn volgens bovenstaande illustratie in serie aan te sluiten.

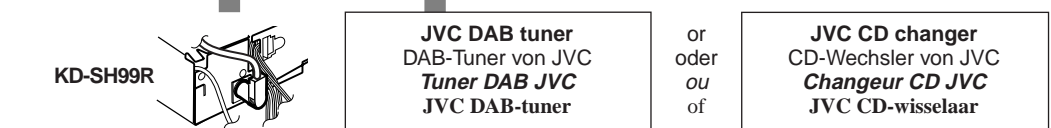

CAUTION / VORSICHT / PRECAUTION / LET OP!

- Before connecting the CD changer and/or the DAB tuner, make sure that the unit is turned off.
- Bevor Sie den CD-Wechsler und/oder den DAB-Tuner anschließen, vergewissern Sie sich, daß das Gerät ausgeschaltet ist.
- Avant de connecter le changeur CD et/ou le tuner DAB, s'assurer que l'unité est éteinte.
- Zorg ervoor dat de apparaat is uitgeschakeld alvorens u de en/of DAB-tuner CD-wisselaar aansluit.

Subwoofer and other source equipment / Subwoofer und andere Komponente / Caisson de grave et autre appareil / Subwoofer en andere apparaat

- You can connect a subwoofer to reinforce the bass.
- Sie können einen Subwoofer zur Baßverstärkung anschließen.
- Vous pouvez connecter les deux appareils en série comme montré ci-dessus.
- Beide apparaten zijn volgens bovenstaande illustratie in serie aan te sluiten.

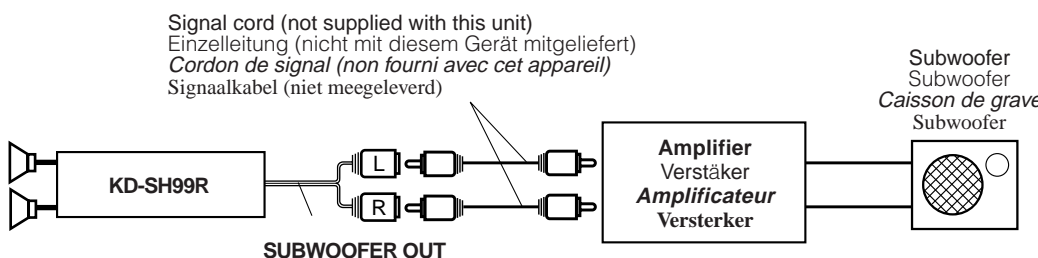

DVD, VCR or TV / DVD, Videorecorder oder Fernsehgerät / DVD, Magnéscope ou Téléviseur / DVD, Videorecorders en TV

Signal cord (not supplied with this unit)
Einzelleitung (nicht mit diesem Gerät mitgeliefert)
Cordon de signal (non fourni avec cet appareil)
Signaalkabel (niet meegeleverd)

You can connect the DVD player (KV-DV7). Sie können den DVD-Spieler (KV-DV7) anschließen. Vous pouvez connecter un lecteur de DVD (KV-DV7). Het is mogelijk een DVD (KV-DV7) aan te sluiten.

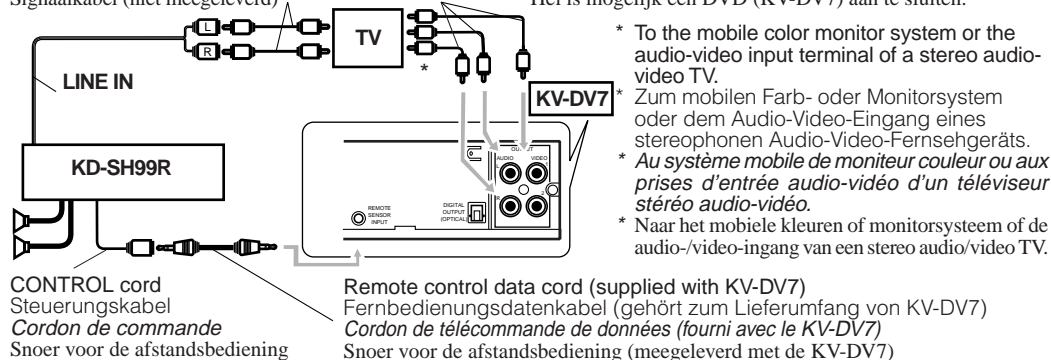

CONTROL cord
Steuerungskabel
Cordon de commande
Snoer voor de afstandsbediening

Remote control data cord (supplied with KV-DV7)
Fernbedienungsdaten kabel (gehört zum Lieferumfang von KV-DV7)
Cordon de télécommande de données (fourni avec le KV-DV7)
Snoer voor de afstandsbediening (meegeleverd met de KV-DV7)